

This manual should be considered a permanent part of the motorcycle and should remain with the motorcycle when it is resold.

This publication includes the latest production information available before printing. Honda Motor Co., Ltd. reserves the right to make changes at any time without notice and without incurring any obligation.

No part of this publication may be reproduced without written permission.

The vehicle pictured in this owner's manual may not match your actual vehicle.

© 2011 Honda Motor Co., Ltd.

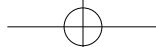

Welcome

Congratulations on your purchase of a new Honda motorcycle. Your selection of a Honda makes you part of a worldwide family of satisfied customers who appreciate Honda's reputation for building quality into every product.

To ensure your safety and riding pleasure:

- Read this owner's manual carefully.
- Follow all recommendations and procedures contained in this manual.
- Pay close attention to safety messages contained in this manual and on the motorcycle.

- The following codes in this manual indicate each country.
- The illustrations here in are based on the ED type.

Country Codes

Code	Country
E	UK
F	France
ED	European direct sales
U	Australia, New Zealand

* The specifications may vary with each locale.



A Few Words About Safety

Your safety, and the safety of others, is very important. Operating this motorcycle safely is an important responsibility.

To help you make informed decisions about safety, we have provided operating procedures and other information on safety labels and in this manual. This information alerts you to potential hazards that could hurt you or others.

Of course, it is not practical or possible to warn you about all hazards associated with operating or maintaining a motorcycle. You must use your own good judgement.

You will find important safety information in a variety of forms, including:

- Safety labels on the motorcycle.
- Safety Messages preceded by a safety alert symbol and one of three signal words: DANGER, WARNING, or CAUTION. These signal words mean:

DANGER

You **WILL** be **KILLED** or **SERIOUSLY HURT** if you don't follow instructions.

WARNING

You **CAN** be **KILLED** or **SERIOUSLY HURT** if you don't follow instructions.

CAUTION

You **CAN** be **HURT** if you don't follow instructions.

Other important information is provided under the following titles:

NOTICE Information to help you avoid damage to your motorcycle, other property, or the environment.

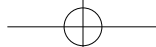

Contents

Motorcycle Safety P. 2

Operation Guide P. 18

Maintenance P. 38

Troubleshooting P. 79

Information P. 98

Specifications P. 111

Index P. 114





Motorcycle Safety

This section contains important information for safe riding of your motorcycle.
Please read this section carefully.

Safety Guidelines	P.3
Image Labels	P.6
Safety Precautions	P.11
Riding Precautions	P.12
Accessories & Modifications	P.16
Loading	P.17



Safety Guidelines

Safety Guidelines

Follow these guidelines to enhance your safety:

- Perform all routine and regular inspections specified in this manual.
- Stop the engine and keep sparks and flame away before filling the fuel tank.
- Do not run the engine in enclosed or partly enclosed areas. Carbon monoxide in exhaust gases is toxic and can kill you.

Always Wear a Helmet

It's a proven fact: helmets and protective apparel significantly reduce the number and severity of head and other injuries. So always wear an approved motorcycle helmet and protective apparel. ➤P.11

Before Riding

Make sure that you are physically fit, mentally focused and free of alcohol and drugs. Check

that you and your passenger are both wearing an approved motorcycle helmet and protective apparel. Instruct your passenger on holding onto the grab rails, leaning with you in turns, and keeping their feet on the footpegs, even when the motorcycle is stopped.

Take Time to Learn & Practice

Even if you have ridden other motorcycles, practice riding in a safe area to become familiar with how this motorcycle works and handles, and to become accustomed to the motorcycle's size and weight.

Ride Defensively

Always pay attention to other vehicles around you, and do not assume that other drivers see you. Be prepared to stop quickly or perform an evasive maneuver.



Safety Guidelines

Make Yourself Easy to See

Make yourself more visible, especially at night, by wearing bright reflective clothing, positioning yourself so other drivers can see you, signaling before turning or changing lanes, and using your horn when necessary.

Ride within Your Limits

Never ride beyond your personal abilities or faster than conditions warrant. Fatigue and inattention can impair your ability to use good judgement and ride safely.

Don't Drink and Ride

Alcohol and riding don't mix. Even one alcoholic drink can reduce your ability to respond to changing conditions, and your reaction time gets worse with every additional drink. Don't drink and ride, and don't let your friends drink and ride either.

Keep Your Honda in Safe Condition

It's important to keep your motorcycle properly maintained and in safe riding condition. Inspect your motorcycle before every ride and perform all recommended maintenance. Never exceed load limits (➤P.17), and do not modify your motorcycle or install accessories that would make your motorcycle unsafe (➤P.16).

If You are Involved in a Crash

Personal safety is your first priority. If you or anyone else has been injured, take time to assess the severity of the injuries and whether it is safe to continue riding. Call for emergency assistance if needed. Also follow applicable laws and regulations if another person or vehicle is involved in the crash.

If you decide to continue riding, first evaluate the condition of your motorcycle. If the engine is still running, turn it off. Inspect for fluid

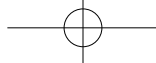

Safety Guidelines

leaks, check the tightness of critical nuts and bolts, and check the handlebar, control levers, brakes, and wheels. Ride slowly and cautiously. Your motorcycle may have suffered damage that is not immediately apparent. Have your motorcycle thoroughly checked at a qualified service facility as soon as possible.

Carbon Monoxide Hazard

Exhaust contains poisonous carbon monoxide, a colourless, odorless gas. Breathing carbon monoxide can cause loss of consciousness and may lead to death.

If you run the engine in a confined or even partly enclosed area, the air you breathe could contain a dangerous amount of carbon monoxide. Never run your motorcycle inside a garage or other enclosure.

WARNING

Carbon monoxide gas is toxic. Breathing it can cause unconsciousness and even kill you.

Avoid any areas or activities that expose you to carbon monoxide.

Motorcycle Safety

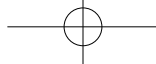

Image Labels

Image Labels

Motorcycle Safety

The following pages describe the label meanings. Some labels warn you of potential hazards that could cause serious injury. Others provide important safety information. Read this information carefully and don't remove the labels.

If a label comes off or becomes hard to read, contact your dealer for a replacement.

There is a specific symbol on each label. The meanings of each symbol and label are as follows.



Read instructions contained in Owner's Manual carefully.



Read instructions contained in Shop Manual carefully. In the interest of safety, take the motorcycle to be serviced only by your dealer.



DANGER (with RED background)

You WILL be KILLED or SERIOUSLY HURT if you don't follow instructions.

WARNING (with ORANGE background)

You CAN be KILLED or SERIOUSLY HURT if you don't follow instructions.

CAUTION (with YELLOW background)

You CAN be HURT if you don't follow instructions.

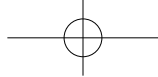
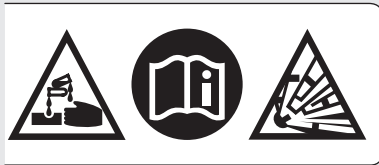

Image Labels



BATTERY LABEL DANGER

- Keep flame and spark away from the battery. Battery produce explosive gas that can cause explosion.
- Wear the eye protection and rubber gloves when handling the battery, or you can get burned or lose your eyesight by the battery electrolyte.
- Do not allow children and other people to touch a battery unless they understand proper handling and hazards of the battery very well.
- Handle the battery electrolyte with extreme care as it contains dilute sulfuric acid. Contact with your skin or eyes can burn you or cause loss of your eyesight.
- Read this manual carefully and understand it before handling the battery. Neglect of the instructions can cause personal injury and damage to the motorcycle.
- Do not use a battery with the electrolyte at or below the lower level mark. It can explode causing serious injury.

continued 7

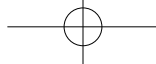

Image Labels

Motorcycle Safety



RADIATOR CAP LABEL

DANGER

NEVER OPEN WHEN HOT.

Hot coolant will scald you.

Relief pressure valve begins to open at **1.1 kgf/cm²**.

ACCESSORIES AND LOADING WARNING LABEL

WARNING

ACCESSORIES AND LOADING

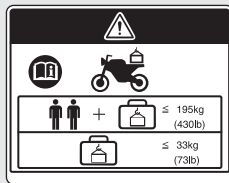

- The safety stability and handling of this motorcycle may be affected by the addition of accessories and luggage.
- Read carefully the instructions contained in user's manual and installation guide before installing any accessory.
- The total weight of accessories and luggage added to rider's and passenger's weight should not exceed **195 kg (430 lb)**, which is the maximum weight capacity.
- The luggage weight must not exceed **33 kg (73 lb)** under any circumstances.
- The fitting of large fork-mounted or large handlebar mounted fairing is not recommended.

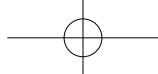

Image Labels



REAR CUSHION LABEL

GAS FILLED

Do not open. Do not heat.

TYRE INFORMATION LABEL

Cold tyre pressure:

[Driver only]

Front **225 kPa (2.25 kgf/cm², 33 psi)**

Rear **250 kPa (2.50 kgf/cm², 36 psi)**

[Driver and passenger]

Front **225 kPa (2.25 kgf/cm², 33 psi)**

Rear **250 kPa (2.50 kgf/cm², 36 psi)**

Tyre size:

Front **120/70R17M/C 58V**

Rear **180/55R17M/C 73V**

Tyre brand: PIRELLI

Front **SCORPION TRAIL**

Rear **SCORPION TRAIL**

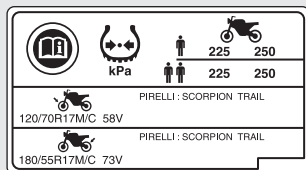

Motorcycle Safety

continued 9

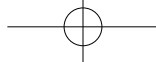

Image Labels

Motorcycle Safety



SAFETY REMINDER LABEL

For your protection, always wear helmet, protective apparel.

FUEL LABEL

Unleaded petrol only



DRIVE CHAIN LABEL

Keep chain adjusted and lubricated.

30 to 40 mm (1.2 to 1.6 in) Freeplay



Safety Precautions

Safety Precautions

- Ride cautiously and keep your hands on the handlebar and feet on the footpegs.
- Keep passenger's hands onto the grab rails, passenger's feet on the footpegs while riding.
- Always consider the safety of your passenger, as well as other drivers and riders.

Protective Apparel

Make sure that you and any passenger are wearing an approved motorcycle helmet, eye protection, and high-visibility protective clothing. Ride defensively in response to weather and road conditions.

■ Helmet

Safety-standard certified, high-visibility, correct size for your head.

- Must fit comfortably but securely, with the chin strap fastened.

- Face shield with unobstructed field of vision or other approved eye protection.

⚠ WARNING

Not wearing a helmet increases the chance of serious injury or death in a crash.

Make sure that you and any passenger always wear an approved helmet and protective apparel.

■ Gloves

Full-finger leather gloves with high abrasion resistance.

■ Boots or Riding Shoes

Sturdy boots with non-slip soles and ankle protection.

■ Jacket and Pants

Protective, highly visible, long-sleeved jacket and durable trousers for riding (or a protective suit).

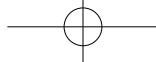

Riding Precautions

Riding Precautions

Motorcycle Safety

Running-in Period

During the first 500 km (300 miles) of running, follow these guidelines to ensure your motorcycle's future reliability and performance.

- Avoid full-throttle starts and rapid acceleration.
- Avoid hard braking.
- Ride conservatively.

Brakes

Observe the following guidelines:

- Avoid excessively hard braking and sudden shifting to a lower gear.
 - ▶ Sudden braking can reduce the motorcycle's stability.
 - ▶ Where possible, reduce speed before turning; otherwise you risk wheel slippage.
- Exercise caution on low traction surfaces.
 - ▶ The wheels lock more easily on such surfaces, and braking distances are longer.
- Avoid continuous braking.
 - ▶ Repeated braking can overheat the brakes, reducing their effectiveness.

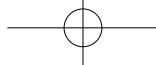

Riding Precautions

Combined ABS

Your motorcycle is equipped with a brake system that distributes the braking force between the front and rear brakes.

The distribution of the braking force applied to the front and rear brakes is different when operating the lever only and when operating the pedal only.

For full braking effectiveness, operate both the lever and pedal together.

This model is also equipped with an Anti-lock Brake System (ABS) designed to help prevent the brakes from locking up during hard braking. Always use the recommended tyres to ensure correct ABS operation.

- ABS does not reduce braking distance. In certain circumstances, ABS may result in a longer stopping distance.
- ABS does not function at speeds below 10 km/h (6 mph).
- The brake lever and pedal may recoil slightly when applying the brakes. This is normal.

Engine Braking

Engine braking helps slow your motorcycle down when you release the throttle. For further slowing action, downshift to a lower gear. Use engine braking with intermittent use of the brakes to reduce speed when descending long, steep slopes.

Wet or Rainy Conditions

Road surfaces are slippery when wet, and wet brakes further reduce braking efficiency. Exercise extra caution when braking in wet conditions.

If the brakes get wet, apply the brakes while riding at low speed to help them dry.



Riding Precautions

Parking

- Park on a firm, level paved surface.
- If you must park on a slight incline or loose surface, park so that the motorcycle cannot move or fall over.
- Make sure that high-temperature parts cannot come into contact with flammable materials.
- Do not touch the engine, muffler, brakes and other high-temperature parts until they cool down.
- To reduce the likelihood of theft, always lock the handlebar and remove the key when leaving the motorcycle unattended. Use of an anti-theft device is also recommended.

Parking with the Side Stand

1. Stop the engine.
2. Push the side stand down.
3. Slowly lean the motorcycle to the left until its weight rests on the side stand.

4. Turn the handlebar fully to the left.
 - ▶ Turning the handlebar to the right reduces stability and may cause the motorcycle to fall.
5. Turn the ignition switch to the LOCK position and remove the key. P.33



Riding Precautions

Refuelling and Fuel Guidelines

Follow these guidelines to protect the engine and catalytic converter:

- Use only unleaded petrol.
- Use recommended octane number. Using lower octane petrol will result in decreased engine performance.
- Do not use fuels containing a high concentration of alcohol.  P.103
- Do not use stale or contaminated petrol or an oil/petrol mixture.
- Avoid getting dirt or water in the fuel tank.

Motorcycle Safety

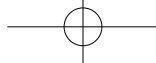

Accessories & Modifications

Motorcycle Safety

Accessories & Modifications

We strongly advise that you do not add any accessories that were not specifically designed for your motorcycle by Honda or make modifications to your motorcycle from its original design. Doing so can make it unsafe. Modifying your motorcycle may also void your warranty and make your motorcycle illegal to operate on public roads and highways. Before deciding to install accessories on your motorcycle be certain the modification is safe and legal.

WARNING

Improper accessories or modifications can cause a crash in which you can be seriously hurt or killed.

Follow all instructions in this owner's manual regarding accessories and modifications.

Do not pull a trailer with, or attach a sidecar to, your motorcycle. Your motorcycle was not designed for these attachments, and their use can seriously impair your motorcycle's handling.



Loading

Loading

- Carrying extra weight affects your motorcycle's handling, braking and stability. Always ride at a safe speed for the load you are carrying.
- Avoid carrying an excessive load and keep within specified load limits.
➤ **Maximum weight capacity / Maximum luggage weight** P.111
- Tie all luggage securely, evenly balanced and close to the centre of the motorcycle.
- Do not place objects near the lights or the muffler.

WARNING

Overloading or improper loading can cause a crash and you can be seriously hurt or killed.

Follow all load limits and other loading guidelines in this manual.

Motorcycle Safety

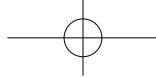

Parts Location

Rear brake fluid reservoir → P.67

Fuse box → P.96

Front brake fluid reservoir

→ P.67

Front brake lever → P.75

Throttle grip → P.74

Coolant reserve tank

→ P.65

Right front side cowl

→ P.57

Engine oil filter → P.63

Engine oil inspection window → P.61

Engine oil fill cap → P.61

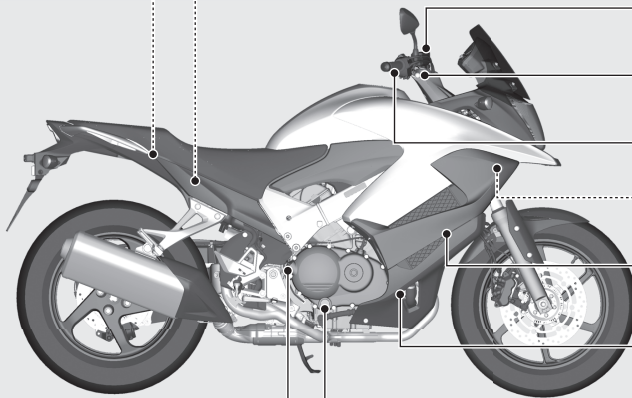

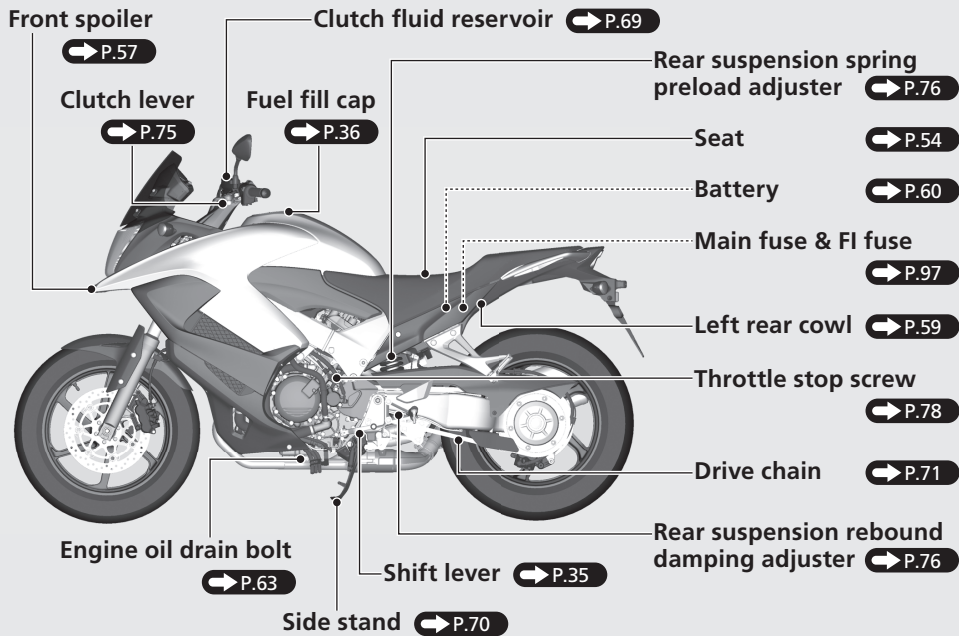
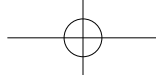



Instruments

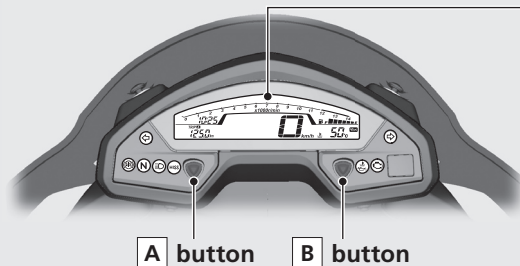

Display Check

When the ignition switch is turned ON, all the mode and digital segments will show, and the tachometer will sweep to 14,000 rpm and go off.

If any part of these displays does not come on when it should, have your dealer check for problems.

Changing the Speed, Mileage and Fuel Mileage Unit

(E type only)

Press and hold **A** and **B** buttons to change the speed, mileage and fuel mileage units ("km/h" & "km" & "km/l" or "mph" & "mile" & "mile/l") for speedometer, odometer, tripmeter and fuel mileage meter.

Press **A** button to select either "km/h" & "km" & "km/l" or "mph" & "mile" & "mile/l", then press **B** button to set. Also you can change the indication mode of fuel mileage.

➔ P.27



Clock (12-hour display)

To set the clock: P.29



Speedometer

Fuel gauge

Remaining fuel when only 1st (E) segment starts flashing:
approximately 4.5 litres
(1.19 US gal, 0.99 Imp gal)



Tachometer

NOTICE

Do not operate the engine in the tachometer red zone. Excessive engine speed can adversely affect engine life.

Tachometer red zone

(excessive engine rpm range)

At the same time, the display switches to the reserve fuel consumption. P.28

If the fuel gauge indicators repeat flashing or turned off: P.84

continued 21

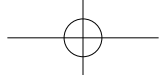

Instruments (Continued)

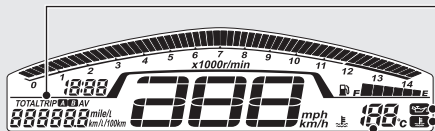

Coolant temperature gauge ()

Display range: 35 to 132 °C

- Below 34 °C: " - - " displays
- Between 122 and 131 °C:
 - High coolant temperature indicator and warning indicator light
 - Coolant temperature gauge (flashing digits)
- Above 132 °C:
 - High coolant temperature indicator and warning indicator light
 - "132" flashes



Low oil pressure indicator

Comes on when the ignition switch is turned ON. Goes off when the engine starts.

If it comes ON while engine is running:  **P.82**



High coolant temperature indicator

Comes on briefly when the ignition switch is turned ON.

If it comes ON while riding:
 **P.81**

- ▶ Even if the engine coolant temperature is low, the cooling fan may start running when you rev up the engine. This is normal.

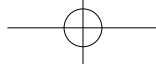

Odometer [TOTAL] & Tripmeter [TRIP A/B]

[A] button switches between odometer & tripmeters.

When the fuel mileage meter is displayed, press [A] button to select the odometer or tripmeter A.

- Odometer: Total distance ridden.
- Tripmeter: Distance ridden since tripmeter was reset.

▶ To reset the tripmeter: P.25

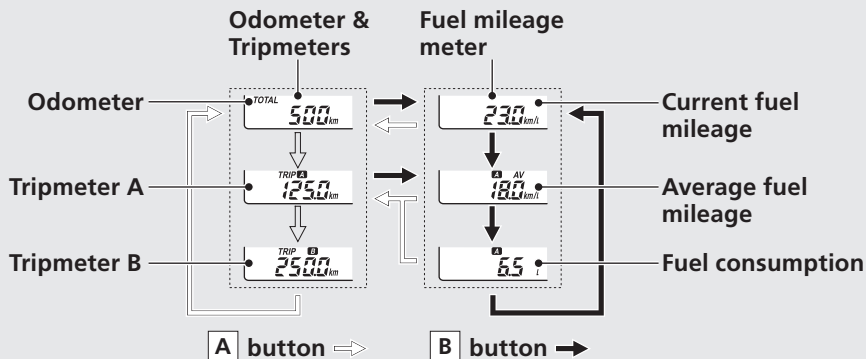

continued 23



Instruments *(Continued)*

Fuel mileage meter

[B] button switches between fuel mileage meters and fuel consumption meter.

When the odometer or tripmeter A is displayed, press **[B]** button to select any mode of the fuel mileage meter. **➔ P.23**

The average fuel mileage and fuel consumption will be based on tripmeter A.

- Current fuel mileage:
Current or instant fuel mileage. If your speed is 1 km/h (0.6 mph) or less, “-.-.-” is displayed.
- Average fuel mileage:
Average fuel mileage since tripmeter A was reset. When “-.-.-” is displayed, go to your dealer for service.
- Fuel consumption:
Total fuel consumption since tripmeter A was reset. When “-.-.-” is displayed, go to your dealer for service.
▶ To reset the average fuel mileage and fuel consumption: ➔ P.25

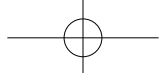

To reset the tripmeter, average fuel mileage and fuel consumption

- 1 To reset tripmeter A, average fuel mileage, and fuel consumption together, press and hold **A** button.

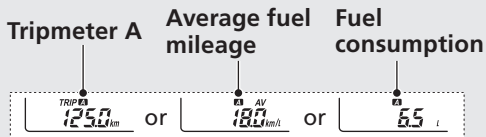

- 2 When they are reset, "0.0" is displayed at each indication.

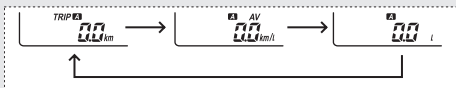

- 3 Then, the display returns to the last selected indication.

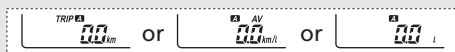

- 4 To reset tripmeter B, press and hold **A** button with tripmeter B displayed.

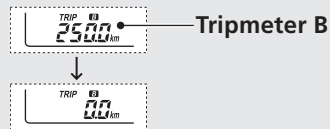

Also, after refuelling more than the reserve amount, the tripmeter A, average fuel mileage, and fuel consumption can be automatically reset.

You can activate or deactivate the automatic reset mode by refuelling.

continued 25

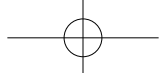

Instruments *(Continued)*

To activate/deactivate the automatic reset mode

You can activate or deactivate the automatic reset by refuelling mode. Initial setting is deactivated.

- 1 Press and hold **B** button, and turn the ignition switch ON. Keep **B** button pressed until the odo/tripmeter segments and units of the multi-function display starts to blink.
- 2 Press **A** button to activate or deactivate the automatic reset mode.

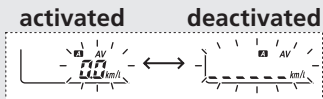

- 3 To end the selection, press **B** button. The display will return to the ordinary conditions.

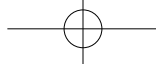

Indication mode of fuel mileage change

When the odometer or tripmeter A is displayed can be set the unit for current and average fuel mileage.

1 Except E type

Press and hold **A** button and **B** button.

E type only

This function can be operated after the speedometer is selected in "km/h".

➡ P.20

The unit in the multi-function display starts to blink.

- 2 Press **A** button to select "km/l" or "l/100km".

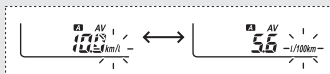

- 3 To end the selection, press **B** button.

continued 27

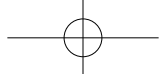

Instruments *(Continued)*

Reserve fuel consumption display

Reserve fuel consumption display automatically switches from other display when the 1st (E) segment of the fuel gauge is flashed.

You should refill the tank as soon as possible.

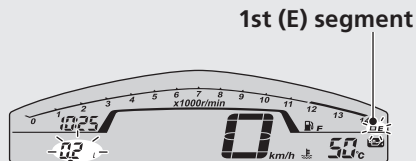

Reserve fuel consumption display

- Flashes from 0.0 "l (litre)".
 - ▶ When the amount of consumed fuel is more than 1.0 litre (0.26 US gal, 0.22 Imp gal) the display blinks faster.
 - ▶ If you change the display to odometer, tripmeter and so on , it will automatically return to the reserve fuel consumption display if the buttons are not pressed for about 10 seconds.

After refuelling more than the reserve amount, the display returns to normal when the ignition switch has been ON for about a minute.

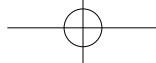

To set the clock:

- 1 Turn the ignition switch ON.
- 2 Press and hold **[B]** button until the hour digits start flashing.

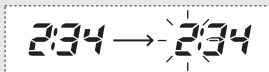

- 3 Press **[A]** button until the desired hour is displayed.
 - ▶ Press and hold to advance the hour fast.

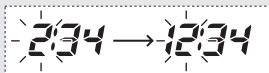

- 4 Press **[B]** button. The minute digits start flashing.

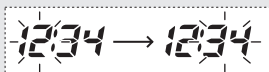

- 5 Press **[A]** button until the desired minute is displayed.
 - ▶ Press and hold to advance the minute fast.



- 6 Press **[B]** button. The clock is set.
 - ▶ The time can also be set by turning the ignition switch OFF.

The display will stop flashing automatically and the adjustment will be cancelled if the button is not pressed for about 30 seconds.

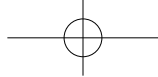

Indicators

ABS (Anti-lock Brake System) indicator

Comes on when the ignition switch is turned ON.
Goes off when your speed reaches approximately 10 km/h (6 mph).

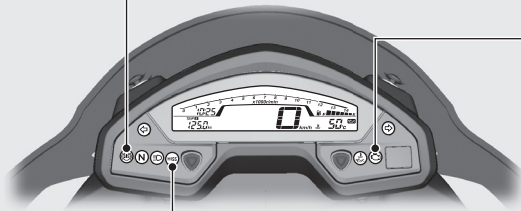

If it comes ON while riding:  **P.83**



HISS indicator **P.100**

- Comes on briefly when the ignition switch is turned ON.
Goes off if the ignition key has the correct coding.
- Flashes every 2 seconds for 24 hours when the ignition switch is turned OFF.

PGM-FI (Programmed Fuel Injection) malfunction indicator lamp (MIL)

Comes on briefly when the ignition switch is turned ON with the engine stop switch in the RUN  position.
If it comes ON while engine is running:  **P.82**



 **Left turn signal indicator**

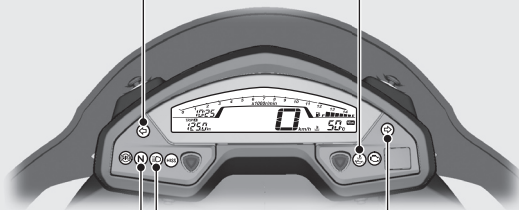

 **Warning indicator**

- Comes on when the ignition switch is turned ON. Goes off when the engine starts.
- Comes on when coolant is over the specified temperature, and/or engine oil pressure is below normal operating range.

If it comes ON while riding (while engine is running):

 P.81  P.82

 **Right turn signal indicator**

 **High beam indicator**

N Neutral indicator
Comes ON when the transmission is in Neutral.

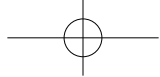

Switches

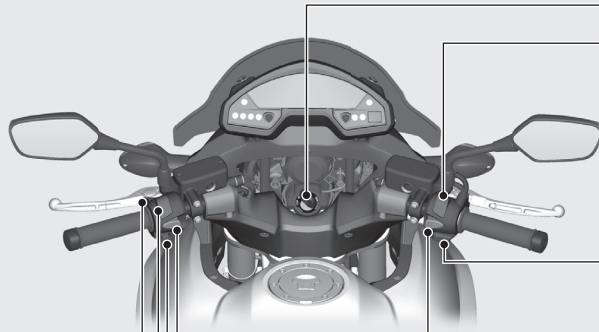



Horn button



Turn signal switch

Headlight dimmer switch

- : High beam
- : Low beam

Passing light control switch

Flashes the high beam headlight.

Engine stop switch

Should normally remain in the RUN  position.

- ▶ In an emergency, switch to the OFF  position to stop the engine.



Start button

Headlight turns off when operating the starter motor.



Hazard switch

Switchable when the ignition switch is ON. Can be turned to OFF regardless of the ignition switch position.

- ▶ The signals continue flashing with the ignition switch in OFF or LOCK after the hazard switch is ON.

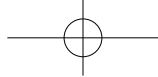

Ignition Switch

Switches the electrical system on/off, locks the steering.

- ▶ Key can be removed when in the OFF or LOCK position.

Steering Lock

Lock the steering when parking to help prevent theft.

A U-shaped wheel lock or similar device is also recommended.

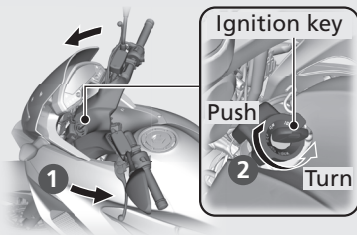

ON

Turns electrical system on for starting/riding.

OFF

Turns engine off.

LOCK

Locks steering.

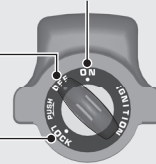

Locking

- 1 Turn the handlebar all the way to the left or right.
- 2 Push the key down, and turn the ignition switch to the LOCK position.
 - ▶ Jiggle the handlebar if the lock is difficult to engage.
- 3 Remove the key.

Unlocking

Insert the key, push it in, and turn the ignition switch to the OFF position.

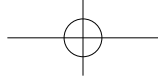

Starting the Engine

Start your engine using the following procedure, regardless of whether the engine is cold or warm.

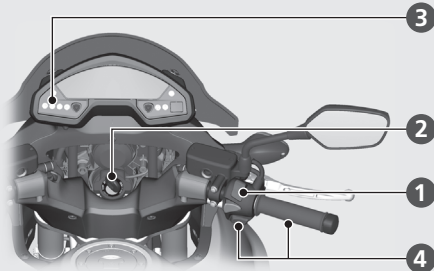

NOTICE

- If the engine does not start within 5 seconds, turn the ignition OFF and wait 10 seconds before trying to start the engine again to recover battery voltage.
- Extended fast idling and revving the engine can damage the engine, and the exhaust system.
- Snapping the throttle or fast idling for more than about 5 minutes may cause exhaust pipe discoloration.

- 1 Make sure the engine stop switch is in the RUN () position.
- 2 Turn the ignition switch to the ON position.
- 3 Shift the transmission to Neutral (N indicator comes ON). Alternatively, pull in the clutch lever to start your motorcycle with the transmission in gear so long as the side stand is raised.
- 4 Press the start button with the throttle completely closed.

If the engine does not start:

- 1 Open the throttle fully and press the start button for 5 seconds.
- 2 Repeat the normal starting procedure.
- 3 If the engine starts, open the throttle slightly if idling is unstable.
- 4 If the engine does not start, wait 10 seconds before trying steps 1 & 2 again.

If Engine Will Not Start → P.80



Shifting Gears

Your motorcycle transmission has six forward gears in a one-down, five-up shift pattern.

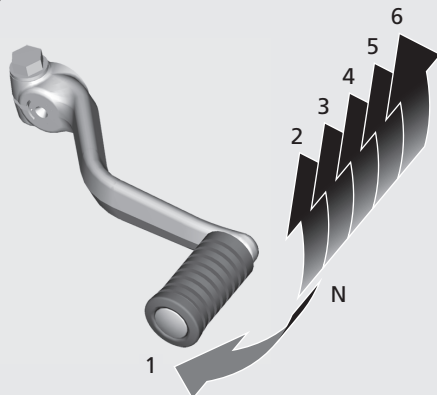

If you put the motorcycle in gear with the side stand down, the engine will shut off.

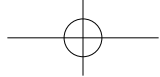

Refuelling

Fuel fill cap

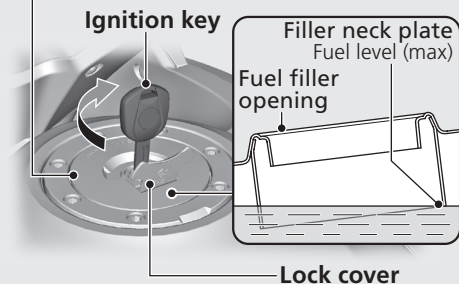

Do not fill with fuel above the plate.

Fuel type: Unleaded petrol only

Fuel octane number: Your motorcycle is designed to use Research Octane Number (RON) 91 or higher.

Tank capacity: 21 litres (5.55 US gal, 4.62 Imp gal)

Refuelling and Fuel Guidelines ➔ P.15

Opening the Fuel Fill Cap

Open the lock cover, insert the ignition key, and turn it clockwise to open the cap.

Closing the Fuel Fill Cap

- 1 After refuelling, push the fuel fill cap closed until it locks.
- 2 Remove the key and close the cover.
 - ▶ The key cannot be removed if the cap is not locked.

⚠ WARNING

Petrol is highly flammable and explosive. You can be burned or seriously injured when handling fuel.

- Stop the engine, and keep heat, sparks, and flame away.
- Handle fuel only outdoors.
- Wipe up spills immediately.

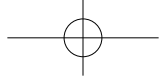

Storage Equipment

The helmet holder, a helmet set wire, a tool kit, and document bag are located under the seat. There is also space to store a U-shaped lock, a rear suspension pin spanner and a extension bar.

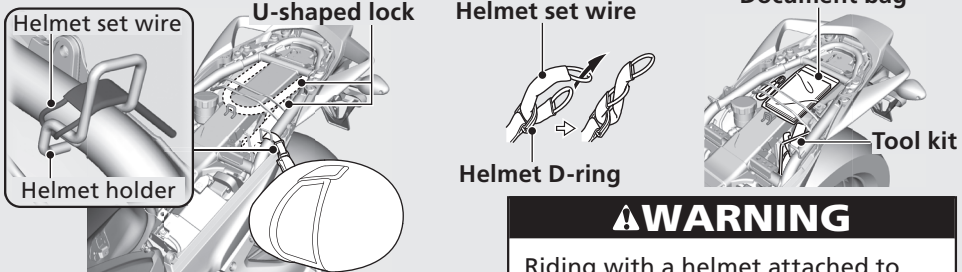

- ▶ For the detailed storage method of the tool kit, refer "Tool kit". ➔ P.53
- ▶ The U-shaped lock is held in place above the rear fender.
- ▶ Use the helmet holder only when parked.
- ▶ Some U-shaped locks may not fit in the compartment due to their size or design.

▶ **Removing the Seat** ➔ P.54

⚠ WARNING

Riding with a helmet attached to the holder can interfere with the rear wheel or suspension and could cause a crash in which you can be seriously hurt or killed.

Use the helmet holder only while parked. Do not ride with a helmet secured by the holder.



Maintenance

Please read “Importance of Maintenance” and “Maintenance Fundamentals” carefully before attempting any maintenance. Refer to “Specifications” for service data.

Importance of Maintenance	P.39	Engine Oil	P.61
Maintenance Schedule	P.40	Coolant	P.65
Maintenance Fundamentals	P.43	Brakes/Clutch	P.67
Tool kit	P.53	Side Stand	P.70
Removing & Installing Body Components	P.54	Drive Chain	P.71
Seat	P.54	Throttle	P.74
Clip A	P.55	Other Adjustments	P.75
Clip B	P.55	Clutch and Brake Levers	P.75
Clip C	P.56	Rear Suspension	P.76
Right Front Side Cowl	P.57	Headlight Aim	P.77
Left Rear Cowl	P.59	Brakelight Switch	P.78
Battery	P.60	Idle Speed	P.78

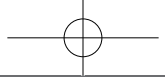

Importance of Maintenance

Importance of Maintenance

Keeping your motorcycle well-maintained is absolutely essential to your safety and to protect your investment, obtain maximum performance, avoid breakdowns, and reduce air pollution. Maintenance is the owner's responsibility. Be sure to inspect your motorcycle before each ride, and perform the periodic checks specified in the Maintenance Schedule. P.40

WARNING

Improperly maintaining your motorcycle or failing to correct a problem before you ride can cause a crash in which you can be seriously hurt or killed.

Always follow the inspection and maintenance recommendations and schedules in this owner's manual.

Maintenance Safety

Always read the maintenance instructions before you begin each task, and make sure that you have the tools, parts, and skills required. We cannot warn you of every conceivable hazard that can arise in performing maintenance. Only you can decide whether or not you should perform a given task.

Follow these guidelines when performing maintenance.

- Stop the engine and remove the key.
- Park your motorcycle on a firm, level surface using the side stand or a maintenance stand to provide support.
- Allow the engine, muffler, brakes, and other high-temperature parts to cool before servicing as you can get burned.
- Run the engine only when instructed, and do so in a well-ventilated area.



Maintenance Schedule

The maintenance schedule specifies the maintenance requirements necessary to ensure safe, dependable performance, and proper emission control.

Maintenance

Maintenance work should be performed in accordance with Honda's standards and specifications by properly trained and equipped technicians. Your dealer meets all of these requirements. Keep an accurate record of maintenance to help ensure that your motorcycle is properly maintained. Make sure that whomever performs the maintenance completes this record.

All scheduled maintenance is considered a normal owner operating cost and will be charged for by your dealer. Retain all receipts. If you sell the motorcycle, these receipts should be transferred with the motorcycle to the new owner.

Honda recommends that your dealer should road test your motorcycle after each periodic maintenance is carried out.

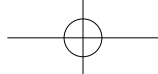

Maintenance Schedule

Items	Frequency	Pre-ride Check P.43	Odometer Reading *1						Annual Check	Regular Replace	Refer to page
			× 1,000 km	1	12	24	36	48			
			× 1,000 mi	0.6	8	16	24	32			
Fuel Line				I	I	I	I	I		-	
Fuel Level		I								-	
Throttle Operation		I		I	I	I	I	I		74	
Air Cleaner *2					R		R			-	
Spark Plug					I		R			-	
Valve Clearance					I		I			-	
Engine Oil		I		R	R	R	R	R	R	61	
Engine Oil Filter				R	R	R	R	R	R	63	
Engine Idle Speed				I	I	I	I	I		78	
Radiator Coolant *3		I		I	I	I	I	I	3 Years	65	
Cooling System				I	I	I	I	I		-	
Secondary Air Supply System				I	I	I	I	I		-	

Maintenance

Maintenance Level

: Intermediate. We recommend service by your dealer, unless you have the necessary tools and are mechanically skilled. Procedures are provided in an official Honda Shop Manual.

: Technical. In the interest of safety, have your motorcycle serviced by your dealer.

Maintenance Legend

I: Inspect (clean, adjust, lubricate, or replace, if necessary)

L: Lubricate

R: Replace

continued 41

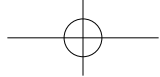

Maintenance Schedule

Items	Frequency	Pre-ride Check P.43	Odometer Reading *1					Annual Check	Regular Replace	Refer to page	
			× 1,000 km	1	12	24	36				48
			× 1,000 mi	0.6	8	16	24				32
Drive Chain		I	Every 1,000 km (600 mi): I L							71	
Drive Chain Slider				I	I	I	I			73	
Brake Fluid *3		I		I	I	I	I	I	2 Years	67	
Brake Pads Wear		I		I	I	I	I	I		68	
Brake System			I	I	I	I	I	I		43	
Brakelight Switch				I	I	I	I	I		78	
Headlight Aim				I	I	I	I	I		77	
Lights/Horn		I								-	
Engine Stop Switch		I								-	
Clutch System				I	I	I	I	I		43	
Clutch fluid *3		I		I	I	I	I	I	2 Years	69	
Side Stand				I	I	I	I	I		70	
Suspension				I	I	I	I	I		76	
Nuts, Bolts, Fasteners			I	I	I	I	I	I		-	
Wheels/Tyres		I		I	I	I	I	I		50	
Steering Head Bearings			I	I	I	I	I	I		-	

Notes:

*1 : At higher odometer readings, repeat at the frequency interval established here.

*2 : Service more frequently when riding in unusually wet or dusty areas.

*3 : Replacement requires mechanical skill.

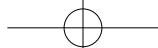

Maintenance Fundamentals

Pre-ride Inspection

To ensure safety, it is your responsibility to perform a pre-ride inspection and make sure that any problem you find is corrected. A pre-ride inspection is a must, not only for safety, but because having a breakdown, or even a flat tyre, can be a major inconvenience.

Check the following items before you ride motorcycle:

- Engine oil-Check levels, add if necessary. ➤P.61
 - Fuel level-Sufficient for intended journey. Refuel when needed. ➤P.36
 - Radiator coolant-Check levels (➤P.65), add if necessary (➤P.66).
 - Lights, horn-Check for correct operation.
 - Brakes-Check operation, brake fluid level and pads wear. ➤P.67, 68
 - Clutch-Check for correct operation and clutch fluid level. ➤P.69
- Drive chain-Check the condition and slack, adjust if necessary and lubricate. ➤P.48, 71
 - Tyres-Check the condition, and air pressures are within limits. ➤P.50
 - Throttle-Check for smooth operation in all steering positions. ➤P.74
 - Engine stop switch-Check for proper function. ➤P.32

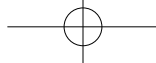

Maintenance Fundamentals

Replacing Parts

Always use Honda Genuine Parts or their equivalents to ensure reliability and safety. When ordering coloured components, specify the model name, colour, and code mentioned on the colour label. The colour label is attached to the frame under the seat. ➤P.54

Maintenance

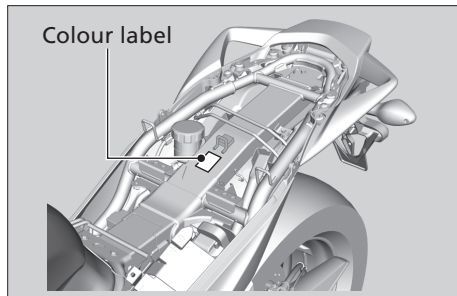

⚠ WARNING

Installing non-Honda parts may make your motorcycle unsafe and cause a crash in which you can be seriously hurt or killed.

Always use Honda Genuine Parts or equivalents that have been designed and approved for your motorcycle.

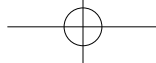

Maintenance Fundamentals

Battery

Your motorcycle has a maintenance-free type battery. You do not have to check the battery electrolyte level or add distilled water. Clean the battery terminals if they become dirty or corroded.

Do not remove the battery cap seals. There is no need to remove the cap when charging.

NOTICE

Your battery is a maintenance-free type and can be permanently damaged if the cap strip is removed.



This symbol on the battery means that this product must not be treated as household waste.

NOTICE

An improperly disposed of battery can be harmful to the environment and human health. Always confirm local regulations for battery disposal.

! WARNING

The battery gives off explosive hydrogen gas during normal operation.

A spark or flame can cause the battery to explode with enough force to kill or seriously hurt you.

Wear protective clothing and a face shield, or have a skilled mechanic do the battery servicing.

I Cleaning the Battery Terminals

1. Remove the battery. ➤P.60
2. If the terminals are starting to corrode and are coated with a white substance, wash with warm water and wipe clean.

continued 45

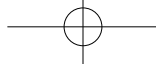

Maintenance Fundamentals

- If the terminals are heavily corroded, clean and polish the terminals with a wire brush or sandpaper. Wear safety glasses.

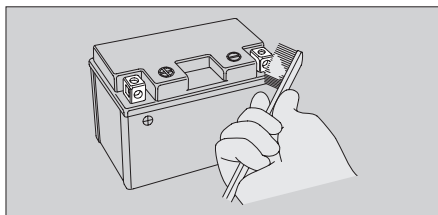

- After cleaning, reinstall the battery.

The battery has a limited life span. Consult your dealer about when you should replace the battery. Always replace the battery with another maintenance-free battery of the same type.

NOTICE

Installing non-Honda electrical accessories can overload the electrical system, discharging the battery and possibly damaging the system.

Fuses

Fuses protect the electrical circuits on your motorcycle. If something electrical on your motorcycle stops working, check for and replace any blown fuses. ➤P.96

Inspecting and Replacing Fuses

Turn off the ignition switch to remove and inspect fuses. If a fuse is blown, replace with a fuse of the same rating. For fuse ratings, see "Specifications." ➤P.113

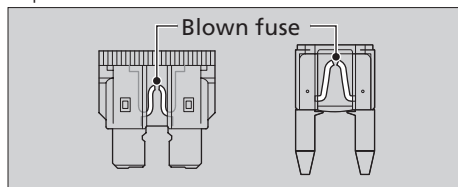

NOTICE

Replacing a fuse with one that has a higher rating greatly increases the chance of damage to the electrical system.

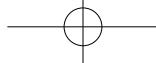

Maintenance Fundamentals

If a fuse fails repeatedly, you likely have an electrical fault. Have your motorcycle inspected by your dealer.

Engine Oil

Engine oil consumption varies and oil quality deteriorates according to riding conditions and time elapsed.

Check the engine oil level regularly, and add the recommended engine oil if necessary. Dirty oil or old oil should be changed as soon as possible.

Selecting the Engine Oil

For recommended engine oil, see “Specifications”. P.112

If you use non-Honda engine oil, check the label to make sure that the oil satisfies all of the following standards:

- JASO T 903 standard*1: MA
- SAE standard*2: 10W-30
- API classification*3: SG or higher

- *1. The JASO T 903 standard is an index for engine oils for 4-stroke motorcycle engines. There are two classes: MA and MB. For example, the following label shows the MA classification.

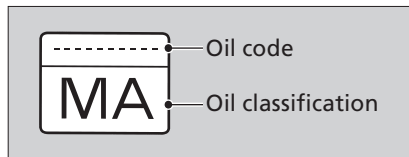

- *2. The SAE standard grades oils by their viscosity.
- *3. The API classification specifies the quality and performance rating of engine oils. Use SG or higher oils, excluding oils marked as “Energy Conserving” on the circular API service symbol.

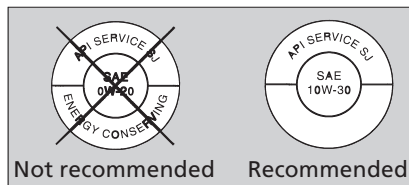

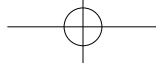

Maintenance Fundamentals

Brake Fluid (Clutch Fluid)

Do not add or replace brake fluid, except in an emergency. Use only fresh brake fluid from a sealed container. If you do add fluid, have the brake system serviced by your dealer as soon as possible.

NOTICE

Brake fluid can damage plastic and painted surfaces. Wipe up spills immediately and wash thoroughly.

Recommended brake fluid:

Honda DOT 4 Brake Fluid or equivalent

Drive Chain

The drive chain must be inspected and lubricated regularly. Inspect the chain more frequently if you often ride on bad roads, ride at high speed, or ride with repeated fast acceleration.

If the chain does not move smoothly, makes strange noises, has damaged rollers or loose pins or missing O-rings, or kinks, have the chain inspected by your dealer.

Also inspect the engine sprocket and rear wheel sprocket. If either has worn or damaged teeth, have the sprocket replaced by your dealer.

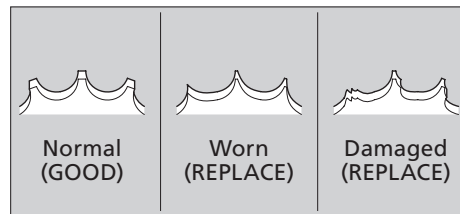

NOTICE

Use of a new chain with worn sprockets will cause rapid chain wear.

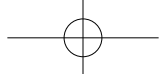

Maintenance Fundamentals

I Cleaning and Lubricating

After inspecting the slack, clean the chain and sprockets while rotating the rear wheel. Use dry cloth with chain cleaner designed specifically for O-ring chains, or neutral detergent. Use a soft brush if the chain is dirty. After cleaning, wipe dry and lubricate with the recommended lubricant. If not available, use SAE 80 or 90 gear oil.

Recommended lubricant:

Drive chain lubricant designed specifically for O-ring chains

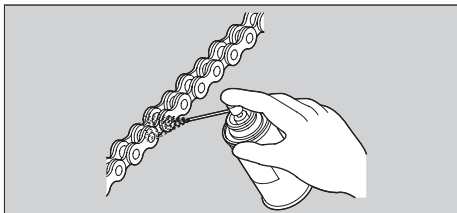

Do not use a steam cleaner, a high pressure cleaner, a wire brush, volatile solvent such as gasoline and benzene, abrasive cleaner, chain cleaner or lubricant NOT designed specifically for O-ring chains as these can damage the rubber O-ring seals. Avoid getting lubricant on the brakes or tyres. Avoid applying excess chain lubricant to prevent spray onto your clothes and the motorcycle.

Recommended Coolant

Pro Honda HP is a pre-mixed solution of antifreeze and distilled water.

Concentration:

50 % antifreeze and 50 % distilled water

continued 49

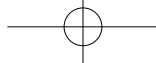

Maintenance Fundamentals

A concentration of antifreeze below 40 % will not provide proper corrosion and cold temperature protection. A concentration of up to 60 % will provide better protection in colder climates.

NOTICE

Using coolant not specified for aluminium engines or using ordinary tap water can cause corrosion.

Tyres (Inspecting/Replacing)

Checking the Air Pressure

Visually inspect your tyres and use an air pressure gauge to measure the air pressure at least once a month or any time you think the tyres look low. Always check air pressure when your tyres are cold.

Inspecting for Damage

Inspect the tyres for cuts, slits, or cracks that exposes fabric or cords, or nails or other foreign objects embedded in the side of the tyre or the tread. Also inspect for the bumps or bulges in the side walls of the tyres.

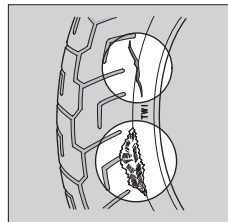

Inspecting for Abnormal Wear

Inspect the tyres for signs of abnormal wear on the contact surface.

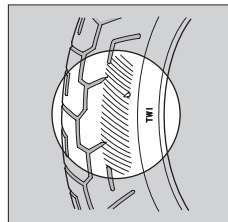

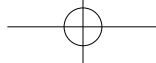

Maintenance Fundamentals

Inspecting Tread Depth

Inspect the tread wear indicators. If they become visible, replace the tyres immediately. For safe riding, you should replace the tyres when the minimum tread depth is reached.

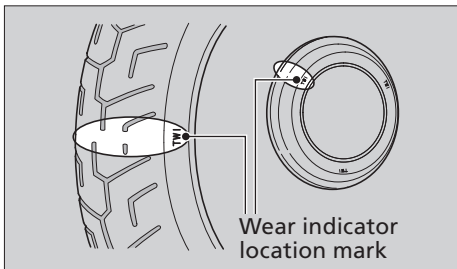

WARNING

Riding on tyres that are excessively worn or improperly inflated can cause a crash in which you can be seriously hurt or killed.

Follow all instructions in this owner's manual regarding tyre inflation and maintenance.

Germany

German law prohibits use of tyres whose tread depth is less than 1.6 mm.

Maintenance

continued 51



Maintenance Fundamentals

Have your tyres replaced by your dealer. For recommended tyres, air pressure and minimum tread depth, see "Specifications".

➤ P.112

Follow these guidelines whenever you replace tyres.

- Use the recommended tyres or equivalents of the same size, construction, speed rating, and load range.
- Have the wheel balanced with Honda Genuine balance weights or equivalents after the tyre is installed.
- Do not install a tube inside a tubeless tyre on this motorcycle. Excessive heat build-up can cause the tube to burst.
- Use only tubeless tyres on this motorcycle. The rims are designed for tubeless tyres, and during hard acceleration or braking, a tube-type tyre could slip on the rim and cause the tyre to rapidly deflate.

WARNING

Installing improper tyres on your motorcycle can adversely affect handling and stability, and can cause a crash in which you can be seriously hurt or killed.

Always use the size and type of tyres recommended in this owner's manual.

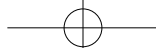

Tool kit

The tool kit is stored under the seat.  P.54

You can perform some roadside repairs, minor adjustments and parts replacement with the tools contained in the kit.

- 8 x 12 mm Open end wrench
- 10 x 14 mm Open end wrench
- Standard/Phillips screwdriver
- Screwdriver grip
- 5 mm Hex wrench
- Fuse puller

The following tools are stored in the compartment as shown.

- Rear suspension adjustment pin spanner
- Extension bar
- Helmet set wire
 - ▶ Be careful not to damage the rear brake reservoir with the loop ends of the helmet set wire.

The following tool is also provided with your motorcycle.

- Drive chain adjustment pin spanner
 - ▶ Store the pin spanner in a safety place.

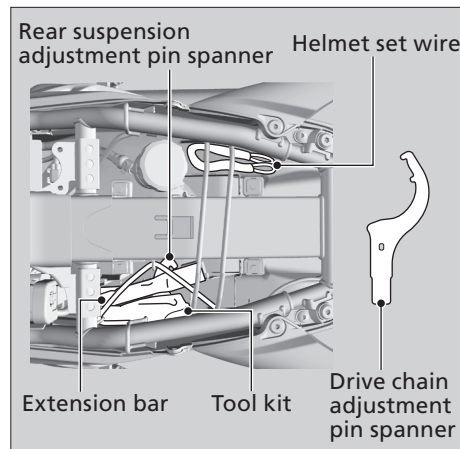

Maintenance

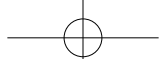

Removing & Installing Body Components

Seat

Maintenance

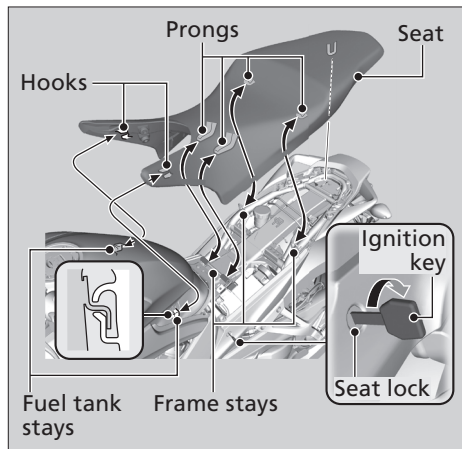

Removal

1. Insert the ignition key into the seat lock, and turn and hold the key clockwise to unlock the seat.
2. Pull the rear of the seat back and up.

Installation

1. Install the seat while aligning its hooks with the fuel tank stays and its prongs with the frame stays.
2. Push forward and down on the rear of the seat until it locks in place.
Make sure that the seat is locked securely in position to pull it up lightly.

The seat locks automatically when closed. Take care not to lock your key in the underseat compartment.

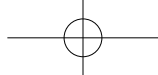

Removing & Installing Body Components ► Clip A

Clip A

The clip A must be removed to remove the spoiler and the right front side cowl.

Removal

1. Press down on the centre pin to release the lock.
2. Pull the clip out of the hole.

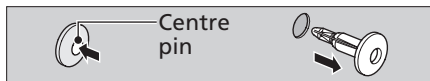

Installation

1. Push the bottom of the centre pin.
2. Insert the clip into the hole.
3. Press down on the centre pin to lock the clip.

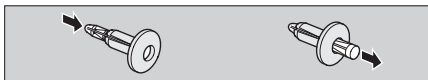

Clip B

The clip B must be removed to remove the right front side cowl.

Removal

1. Press down on the centre pin to release the lock.
2. Pull the clip out of the hole.

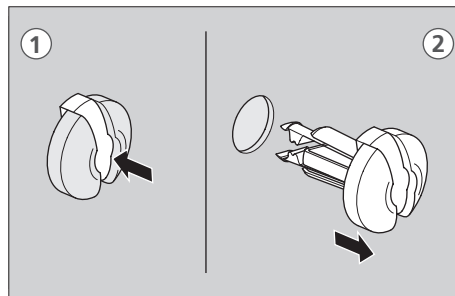

continued 55

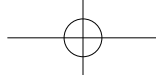

Removing & Installing Body Components ► Clip C

Installation

1. Slightly open the retaining pawls and then push them out.
2. Insert the clip into the hole.
3. Lightly press down on the centre pin to lock the clip.

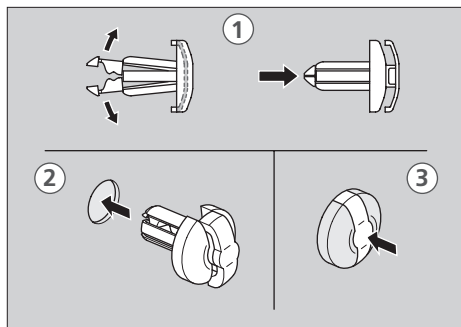

Clip C

The clip C must be removed to remove the left rear cowl.

Removal

1. Remove the pin by a Phillips screwdriver.
2. Pull the clip out of the hole.

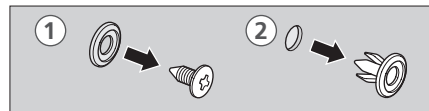

Installation

1. Insert the clip into the hole.
2. Push the pin in.

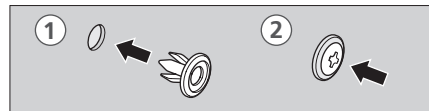

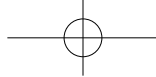

Removing & Installing Body Components ► Right Front Side Cowl

Right Front Side Cowl

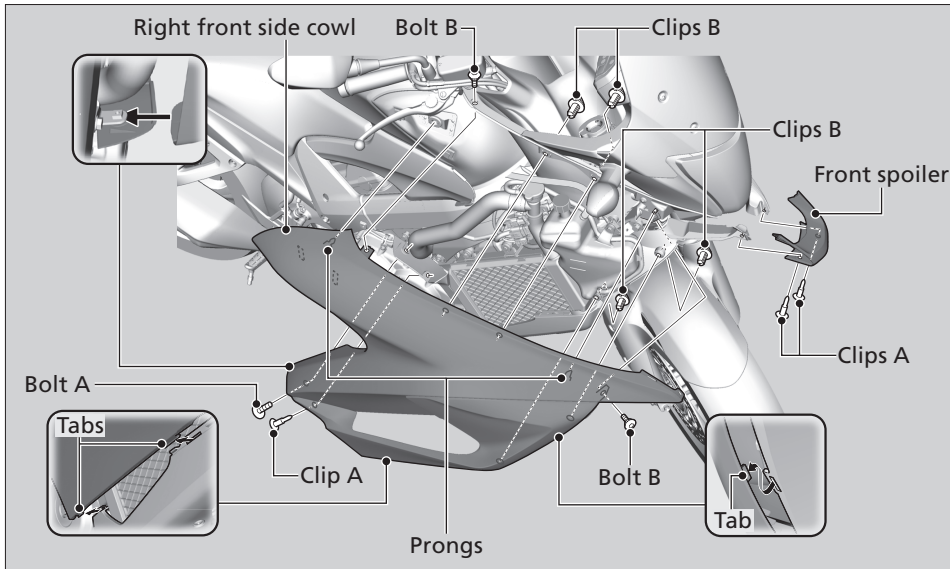

Maintenance

continued 57

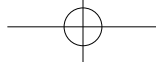

Removing & Installing Body Components ► Right Front Side Cowl

The right front side cowl must be removed to service the coolant reserve tank.

■ Removal

1. Remove the clips A and front spoiler.
2. Remove the clip A, clips B, bolt A and bolts B from the right front side cowl.
3. Release the tabs from the slots.
► Carefully release the tabs.
4. Remove the prongs from the grommets.
5. Remove the right front side cowl.
► Be careful not to apply weight to the front side cowl.

■ Installation

Install the parts in the reverse order of removal.

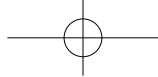

Removing & Installing Body Components ► Left Rear Cowl

Left Rear Cowl

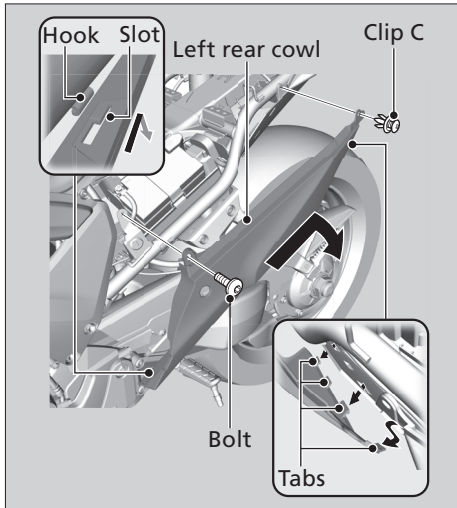

The left rear cowl must be removed to remove the battery.

■ Removal

1. Remove the seat. ►P.54
2. Remove the clip C and bolt.
3. Release the rear cowl tabs from the rear fender slots.
 - Carefully release the tabs.
4. Release the hook from the slot by pulling the left rear cowl back, then remove the left rear cowl.
 - Be careful not to apply weight to the rear cowl.

■ Installation

Install the parts in the reverse order of removal.

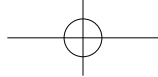

Removing & Installing Body Components ► Battery

Battery

Maintenance

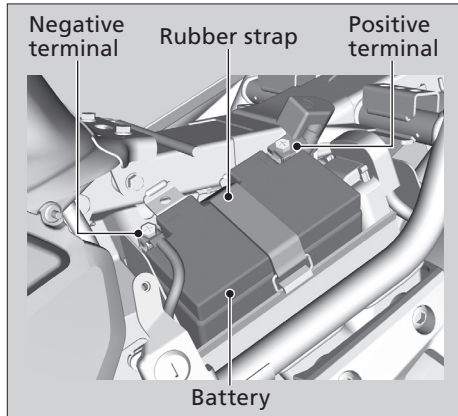

■ Removal

Make sure the ignition switch is OFF.

1. Remove the left rear cowl. ➤P.59
2. Unhook the rubber strap.

3. Disconnect the negative \ominus terminal from the battery.
4. Disconnect the positive \oplus terminal from the battery.
5. Remove the battery taking care not to drop the terminal nuts.

■ Installation

Install the parts in the reverse order of removal. Always connect the positive \oplus terminal first. Make sure that bolts and nuts are tight.

The clock will be reset 1:00 if the battery is disconnected.

For proper handling of the battery, see "Maintenance Fundamentals". ➤P.43
"Battery Goes Dead". ➤P.92



Engine Oil

Checking the Engine Oil

1. If the engine is cold, idle the engine for 3 to 5 minutes.
2. Turn the ignition switch OFF, stop the engine and wait 2 to 3 minutes.
3. Place your motorcycle in an upright position on a firm, level surface.
4. Check that the oil level is between the upper and lower level marks in the oil inspection window.

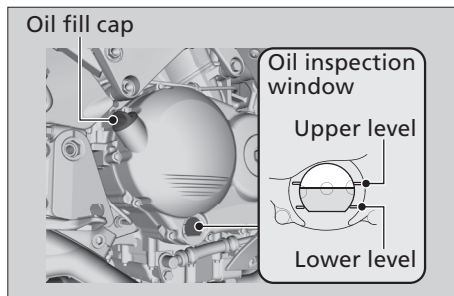

Maintenance



Engine Oil ► Adding Engine Oil

Adding Engine Oil

If the engine oil is below or near the lower level mark, add the recommended engine oil. ►P.47

1. Remove the oil fill cap. Add the recommended oil until it reaches the upper level mark.
 - Place your motorcycle in an upright position on a firm, level surface when checking the oil level.
 - Do not overfill above the upper level mark.
 - Make sure no foreign objects enter the oil filler opening.
 - Wipe up any spills immediately.
2. Securely reinstall the oil fill cap.

NOTICE

Overfilling with oil or operating with insufficient oil can cause damage to your engine. Do not mix different brands and grades of oil. They may affect lubrication and clutch operation.

For the recommended oil and oil selection guidelines, see “Maintenance Fundamentals”. ►P.43

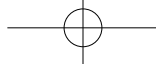

Changing Engine Oil & Filter

Changing the oil and filter requires special tools. We recommend that you have your motorcycle serviced by your dealer.

Use a new Honda Genuine oil filter or equivalent specified for your model.

NOTICE

Using the wrong oil filter can result in serious damage to the engine.

1. If the engine is cold, idle the engine for 3 to 5 minutes.
2. Turn the ignition switch OFF, stop the engine and wait for 2 to 3 minutes.
3. Park on a firm, level surface and lower the side stand.
4. Place a drain pan under the drain bolt.

Engine Oil ► Changing Engine Oil & Filter

5. Remove the oil fill cap, drain bolt, and sealing washer to drain the oil.

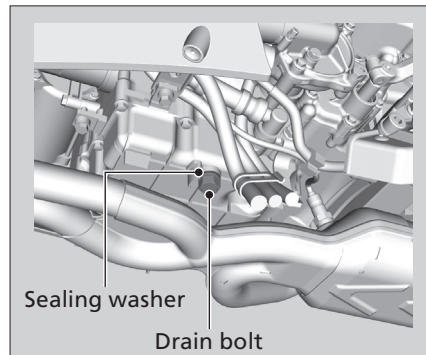

continued 63

Engine Oil ► Changing Engine Oil & Filter

6. Remove the oil filter with a filter wrench and let the remaining oil drain out. Make sure the prior seal is not stuck to the engine.

► Discard the oil and oil filter at an approved recycling centre.

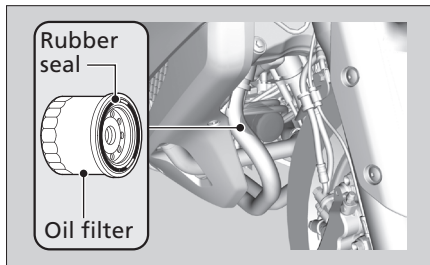

7. Apply a thin coat of engine oil to the rubber seal of a new oil filter.
8. Install a new oil filter and tighten.

Torque: 26 N·m (2.7 kgf·m, 19 lbf·ft).

9. Replace the sealing washer. Install the drain bolt and tighten.

Torque: 30 N·m (3.1 kgf·m, 22 lbf·ft).

10. Fill the crankcase with the recommended oil (►P.47) and install the oil fill cap.

Required oil

When changing oil & engine oil filter:

3.1 litres (3.3 US qt, 2.7 Imp qt)

When changing oil only:

2.9 litres (3.1 US qt, 2.6 Imp qt)

11. Check the oil level. ►P.61

12. Check that there are no oil leaks.

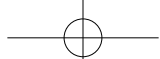

Coolant

Checking the Coolant

1. Place your motorcycle on a firm, level surface.
2. Hold your motorcycle in an upright position.
3. Check that the coolant level is between the upper and lower level marks in the reserve tank.

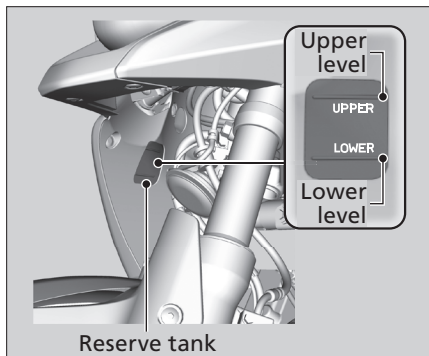

If the coolant level is dropping noticeably or the reserve tank is empty, you likely have a serious leak. Have your motorcycle inspected by your dealer.

Adding Coolant

1. If the coolant level is below the lower level, add the recommended coolant (➤P.49) until the level reaches the upper level mark.
Add fluid only from the reserve tank cap and do not remove the radiator cap.
2. Remove the right front side cowl. ➤P.57

continued 65

Coolant ► Changing Coolant

3. Remove the reserve tank cap and add fluid while monitoring the coolant level.
 - Do not overfill above the upper level mark.
 - Make sure no foreign objects enter the reserve tank opening.
4. Securely reinstall the cap.
5. Install the right front side cowl.

⚠ WARNING

Removing the radiator cap while the engine is hot can cause the coolant to spray out, potentially scalding you.

Always let the engine and radiator cool down before removing the radiator cap.

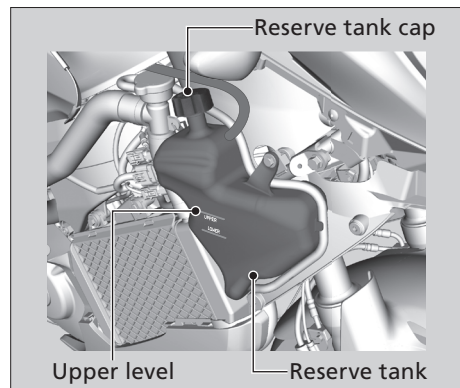

Changing Coolant

Have your dealer change the coolant unless you have the proper tools and are mechanically qualified.

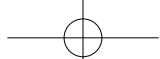

Brakes/Clutch

Checking Brake Fluid

1. Place your motorcycle in an upright position on a firm, level surface.
2. **Front** Check that the brake fluid reservoir cap is horizontal and that the fluid level is above the lower level mark.
3. **Rear** Remove the seat. ➤P.54
4. **Rear** Check that the brake fluid reservoir is horizontal and that the level is between the lower level and upper level marks.

If the brake fluid level in either reservoir is below the lower level mark or the brake lever and pedal freeplay becomes excessive, inspect the brake pads for wear. If the brake pads are not worn, you most likely have a leak. Have your motorcycle inspected by your dealer.

Front

Front brake fluid reservoir

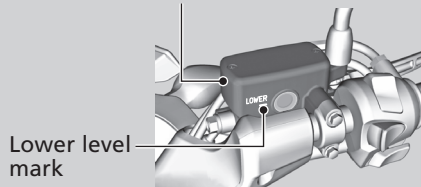

Rear

Rear brake fluid reservoir

Upper level mark

Lower level mark

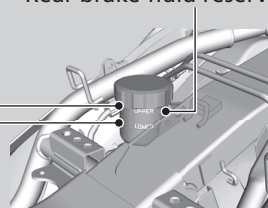

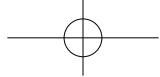

Brakes/Clutch ► Inspecting the Brake Pads

Inspecting the Brake Pads

Check the condition of the brake pad groove wear indicators.

Front The pads need to be replaced if a brake pad is worn to the indicator.

Rear The pads need to be replaced if a brake pad is worn to the bottom of the indicator.

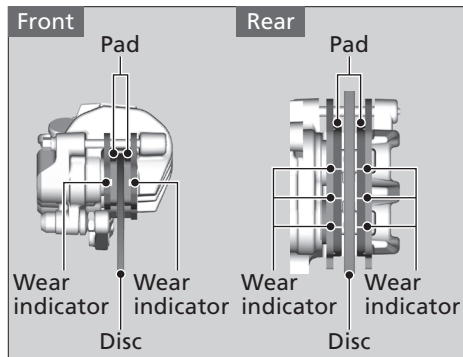

1. **Front** Inspect the brake pads from below the brake caliper.
► Always inspect both left and right calipers.

2. **Rear** Inspect the brake pads from the rear right and left of the motorcycle.
If necessary have the pads replaced by your dealer.

Always replace both left and right brake pads at the same time.

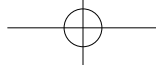
**Brakes/Clutch ▶ Checking Clutch Fluid**

Checking Clutch Fluid

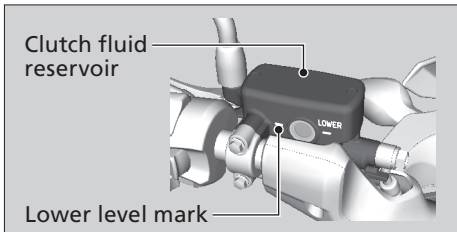

1. Place your motorcycle in an upright position on a firm, level surface.
2. Check that the clutch fluid reservoir cap is horizontal and that the fluid level is above the lower level mark.

If the fluid level is low or if you find fluid leaks, or deterioration or cracks in the hoses and fittings, have the clutch system serviced by your dealer.

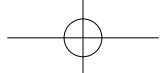

Side Stand

Maintenance

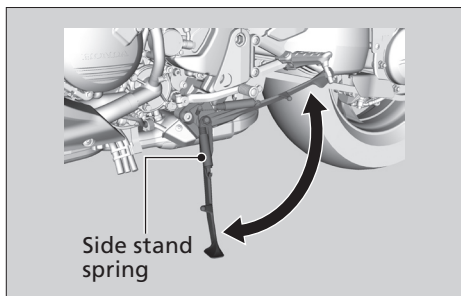

1. Check that the side stand operates smoothly. If the side stand is stiff or squeaky, clean the pivot area and lubricate the pivot bolt with clean grease.
2. Check the spring for damage or loss of tension.
3. Sit on the motorcycle, put the transmission in Neutral, and raise the side stand.
4. Start the engine, pull the clutch lever in, and shift the transmission into gear.
5. Lower the side stand all the way. The engine should stop as you lower the side stand. If the engine doesn't stop, have your motorcycle inspected by your dealer.

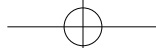

Drive Chain

Inspecting the Drive Chain Slack

Check the drive chain slack at several points along the chain. If the slack is not constant at all points, some links may be kinked and binding.

Have the chain inspected by your dealer.

1. Place your motorcycle on the side stand on a level surface.
2. Stop the engine. Place the transmission in Neutral.

3. Check the slack in the lower half of the drive chain midway between the sprockets.

Drive chain slack:

30 to 40 mm (1.2 to 1.6 in)

- ▶ Do not ride your motorcycle if the slack exceeds 50 mm (2.0 in).

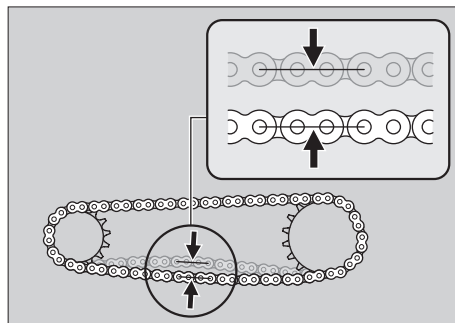

4. Roll the motorcycle forward and check that the chain moves smoothly.

continued 71

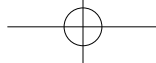

Drive Chain ► Adjusting the Drive Chain Slack

5. Inspect the sprockets. P.48
6. Clean and lubricate the drive chain. P.49

Adjusting the Drive Chain Slack

Adjusting the chain requires special tools. Have the drive chain slack adjusted by your dealer.

1. Stop the engine. Place the transmission in Neutral.
2. Support your motorcycle securely and raise the rear wheel off the ground using a maintenance stand or a hoist.
3. Loosen the bearing holder pinch bolt.
4. Turn the bearing holder clockwise or counterclockwise to obtain the proper chain slack with the pin spanner and extension bar.

5. Tighten the bearing holder pinch bolt to the specified torque.

Torque: 74 N·m (7.5 kgf·m, 55 lbf·ft).

If a torque wrench is not used for this installation, see your dealer as soon as possible to verify proper assembly. Improper assembly may lead to loss of braking capacity.

6. Check drive chain slack. P.71

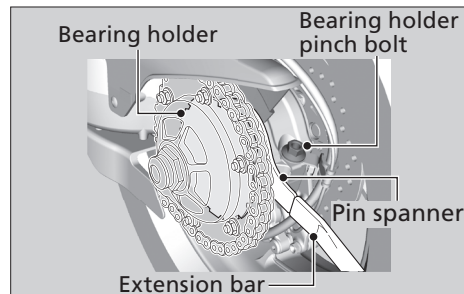

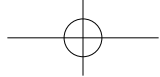

Checking the Drive Chain Wear

Check the chain wear label when adjusting the drive chain. If the red zone on the label aligns with the tip of driven sprocket teeth after the chain has been adjusted to the proper slack, the chain is excessively worn and must be replaced.

Chain: DID 50VA8 or RK 50HFOZ5

If necessary have the drive chain replaced by your dealer.

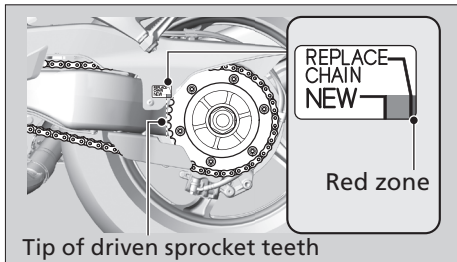

Drive Chain ▶ Checking the Drive Chain Slider

Checking the Drive Chain Slider

Check the condition of the drive chain slider. The drive chain slider need to be replaced if it is worn to the wear limit line. If necessary have the drive chain slider replaced by your dealer.

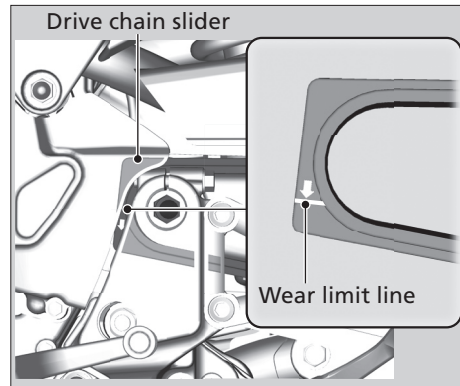

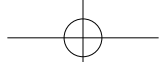

Throttle

Checking the Throttle

With the engine off, check that the throttle rotates smoothly from fully closed to fully open in all steering positions and throttle freeplay is correct. If the throttle does not move smoothly, close automatically, or if the cable is damaged, have the motorcycle inspected by your dealer.

Freeplay at the throttle grip flange:
4 to 6 mm (0.16 to 0.24 in)

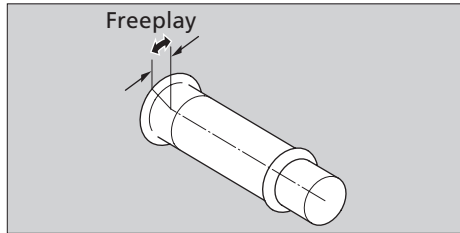

Adjusting the Throttle Freeplay

1. Loosen the lock nut.
2. Turn the adjuster until the freeplay is 4 to 6 mm (0.16 to 0.24 in).
3. Tighten the lock nut and inspect the throttle action again.

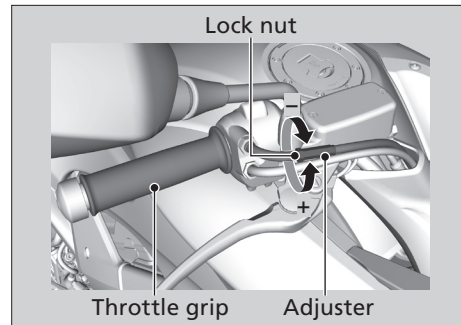

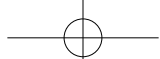

Other Adjustments

Adjusting the Clutch and Brake Levers

You can adjust the distance between the tip of the clutch and brake lever.

Adjustment method

Turn the adjuster until the numbers aligns with the index mark while pushing the lever

forward in the desired position.
After adjustment, check that the levers operate correctly before riding.

NOTICE

- Do not turn the adjuster beyond its natural limit.

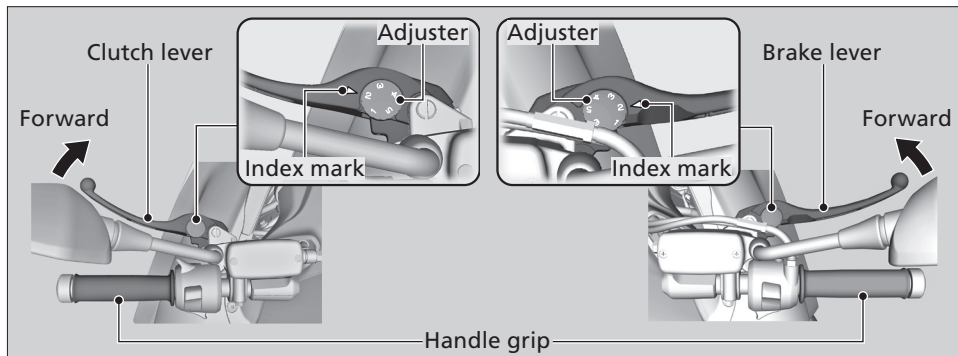

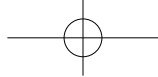

Other Adjustments ► Adjusting the Rear Suspension

Adjusting the Rear Suspension

Spring Preload

You can adjust the spring preload by the adjuster to suit the load or the road surface. Use the pin spanner and extension bar to turn the adjuster. Position 1 is for a decrease spring preload (soft), or turn the position 3 to 7 increase spring preload (hard). The standard position is 2.

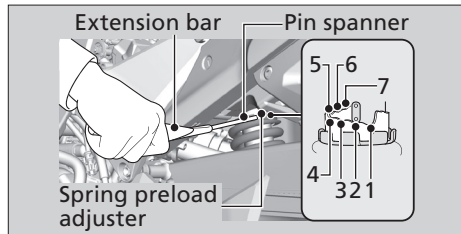

Attempting to adjust directly from 1 to 7 or 7 to 1 may damage the shock absorber.

Rebound Damping

You can adjust the rebound damping by the adjuster to suit the load or the road surface. Turn clockwise to increase rebound damping (hard), or turn counterclockwise to decrease rebound damping (soft). The standard position is approximately 1 1/2 turns from the maximum setting so that the punch mark on the adjuster aligns with the reference punch mark.

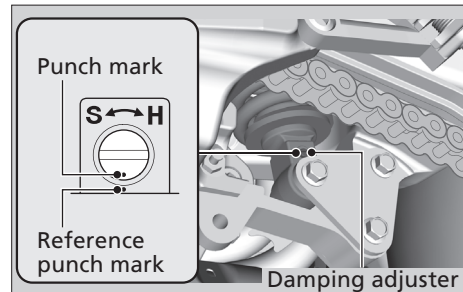



Other Adjustments ► Adjusting the Headlight Aim

NOTICE

Do not turn the adjuster beyond its limits.

NOTICE

The rear shock absorber damper unit contains high pressure nitrogen gas. Do not attempt to disassemble, service, or improperly dispose of the damper. See your dealer.

Adjusting the Headlight Aim

You can adjust vertical aim of the headlight for proper alignment. Turn the screw using a Phillips screwdriver provided in the tool kit (►P.53) in or out as necessary.

Obey local laws and regulations.

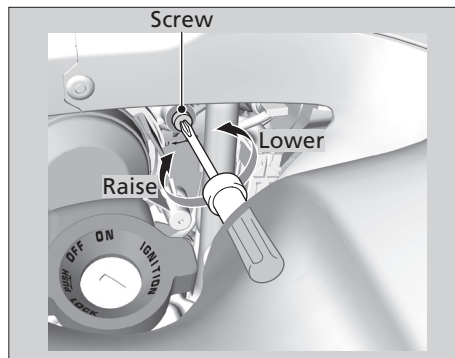

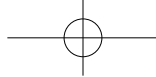

Other Adjustments ► Adjusting the Brakelight Switch

Adjusting the Brakelight Switch

Check the operation of the brakelight switch. Turn the adjusting nut in the direction A if the switch operates too late, or turn the nut in the direction B if the switch operates too soon.

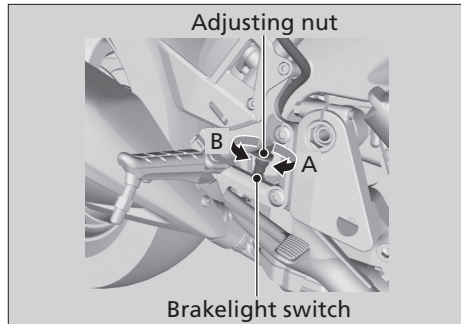

Adjusting the Idle Speed

The engine must be at normal operating temperature for accurate idle speed adjustment. 10 minutes of stop-and-go riding is sufficient.

1. Warm up the engine, shift to neutral and place your motorcycle on the side stand on a level surface.
2. Adjust idle speed with the throttle stop screw.

Idle speed (In neutral):

1,200 ± 100 rpm

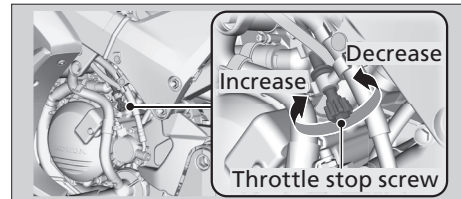

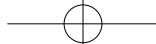

Troubleshooting

Engine Will Not Start	
(HISS indicator stays ON)	P.80
Overheating	
(High coolant temperature/ warning indicators are ON)	P.81
Warning Indicators ON or Flashing	P.82
Low Oil Pressure Indicator.....	P.82
PGM-FI (Programmed Fuel Injection)	
Malfunction Indicator Lamp (MIL).....	P.82
ABS Indicator (Anti-lock Brake System).....	P.83
Other Warning Indication	P.84
Fuel Gauge Failure Indication.....	P.84

Tyre Puncture	P.85
Electrical Trouble	P.92
Battery Goes Dead.....	P.92
Burned-out Light Bulb.....	P.92
Blown Fuse.....	P.96

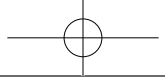

Engine Will Not Start (HISS indicator stays ON)

Starter Motor Operates But Engine Does Not Start

Check the following items:

- Check the correct engine starting sequence. [▶P.34](#)
- Check that there is petrol in the fuel tank.
- Check if the PGM-FI malfunction indicator lamp (MIL) is ON.
 - ▶ If the indicator light is ON, contact your dealer as soon as possible.
- Check if the HISS indicator stays ON.
 - ▶ Turn the ignition switch to the OFF position and remove the key. Reinsert the key and turn the ignition switch to the ON position. If the indicator still stays ON, check the following:

Check if there is no another HISS key (including spare key) close to the ignition switch.

Check if there are no any metallic seals or stickers on the key.

If the HISS indicator still stays ON, have your motorcycle inspected by your dealer.

Starter Motor Does Not Operate

Check the following items:

- Make sure engine stop switch is RUN  position. [▶P.32](#)
- Check for a blown fuse. [▶P.96](#)
- Check for a loose battery connection or battery terminal corrosion. [▶P.60](#)
- Check the condition of the battery. [▶P.92](#)

If the problem continues, have your motorcycle inspected by your dealer.



Overheating (High coolant temperature/warning indicators are ON)

The engine is overheating when the following occurs:

- High coolant temperature indicator and warning indicator come ON.
- Acceleration becomes sluggish.
- If this occurs, pull safely to the side of the road and perform the following procedure.

Extended fast idling may cause the high coolant temperature indicator and warning indicator come ON.

NOTICE

Continuing to ride with an overheated engine can cause serious damage to the engine.

1. Stop the engine using the ignition switch, and then turn the ignition switch to the ON position.

2. Check that the radiator fan is operating, and then turn the ignition switch to the OFF position.

If the fan is not operating:

Suspect a fault. Do not start the engine. Transport your motorcycle to your dealer.

If the fan is operating:

Allow the engine to cool with the ignition switch in the OFF position.

3. After the engine has cooled, inspect the radiator hose and check if there is a leak.

➤P.65

If there is a leak:

Do not start the engine. Transport your motorcycle to your dealer.

4. Check the coolant level in the reserve tank, and add coolant as necessary.

➤P.65

5. If 1-4 check normal, you may continue riding, but closely monitor the temperature gauge.



Warning Indicators ON or Flashing

Low Oil Pressure Indicator

If the low oil pressure indicator and the warning indicator come ON, pull safely to the side of the road and stop the engine.

NOTICE

Continuing to ride with low oil pressure can cause serious damage to the engine.

1. Check the engine oil level, and add oil as necessary. ➤P.61
2. Start the engine.
 - ▶ Only continue riding if the low oil pressure indicator and the warning indicator go OFF.

Rapid acceleration may momentarily cause the low oil pressure indicator and the warning indicator to come ON, especially if the oil is at or near the low level.

If the low oil pressure indicator and the warning indicator stay ON when the oil level is at the proper level, stop the engine and contact your dealer.

If the engine oil level goes down rapidly, your motorcycle may have a leak or another serious problem. Have your motorcycle inspected by your dealer.

PGM-FI (Programmed Fuel Injection) Malfunction Indicator Lamp (MIL)

If the indicator comes ON while riding, you may have a serious problem with the PGM-FI system. Reduce speed and have your motorcycle inspected by your dealer as soon as possible.

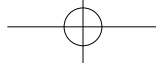

Warning Indicators ON or Flashing ► ABS (Anti-lock Brake System) Indicator

ABS (Anti-lock Brake System) Indicator

If the indicator operates in one of the following ways, you may have a serious problem with the brake system. Reduce your speed and have your motorcycle inspected by your dealer as soon as possible.

- Indicator comes ON or starts flashing while riding.
- Indicator does not come ON when the ignition switch is in the ON position.
- Indicator does not go OFF at speeds above 10 km/h (6 mph).

If the ABS indicator stays ON, your brakes will continue to work as a conventional system, but without the anti-locking function.

The ABS indicator may flash if you turn the rear wheel while your motorcycle is lifted off the ground. In this case, turn the ignition switch OFF and then ON again. The ABS indicator will go OFF after your speed reaches 30 km/h (19 mph).

Troubleshooting

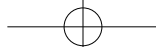

Other Warning Indication

Fuel Gauge Failure Indication

If the fuel system has an error, the fuel gauge indicators will be displayed as shown in the illustration.

If this occurs, see your dealer as soon as possible.

Troubleshooting

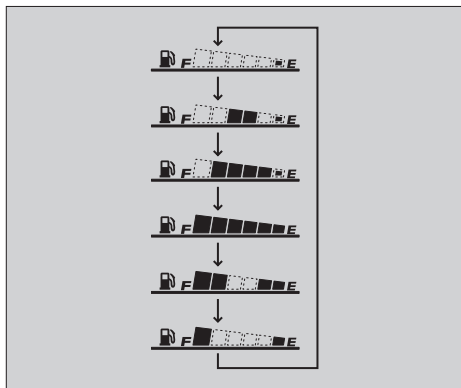

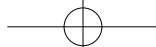

Tyre Puncture

Repairing a puncture or removing a wheel requires special tools and technical expertise. We recommend you have this type of service performed by your dealer. After an emergency repair, always have the tyre inspected/replaced by your dealer.

Emergency Repair Using a Tyre Repair Kit

If your tyre has a minor puncture, you can make an emergency repair using a tubeless tyre repair kit.

Follow the instructions provided with the emergency tyre repair kit.

Riding your motorcycle with a temporary tyre repair is very risky. Do not exceed 50 km/h (30 mph). Have the tyre replaced by your dealer as soon as possible.

WARNING

Riding your motorcycle with a temporary tyre repair can be risky. If the temporary repair fails, you can crash and be seriously injured or killed.

If you must ride with a temporary tyre repair, ride slowly and carefully and do not exceed 50 km/h (30 mph) until the tyre is replaced.

Troubleshooting

Removing Wheels

Follow these procedures if you need to remove the wheel in order to repair a puncture.

continued 85

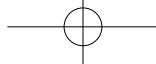

Tyre Puncture ► Removing Wheels

When removing and installing the wheel, be careful not to damage the wheel speed sensor and pulser ring.

Front Wheel

Removal

1. Park on a firm, level surface.
2. Cover both sides of the front wheel and brake caliper with protective tape or cloth.

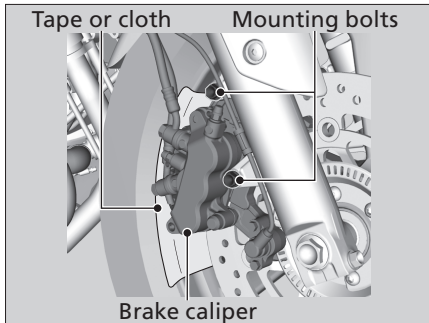

3. On the right side, remove the mounting bolts and remove the brake caliper.
4. On the left side, remove the mounting bolts and remove the brake caliper.
 - Support the brake caliper assembly so that it doesn't hang from the brake hose. Do not twist the brake hose.
 - Avoid getting grease, oil, or dirt on the disc or pad surfaces.
 - Do not pull the brake lever or push the brake pedal while the brake caliper is removed.
 - Take care to prevent the brake caliper from scratching the wheel during removal.

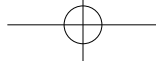

Tyre Puncture ► Removing Wheels

5. Remove the front axle bolt.
6. Loosen the right axle pinch bolt.
7. Support your motorcycle securely and raise the front wheel off the ground using a maintenance stand or a hoist.

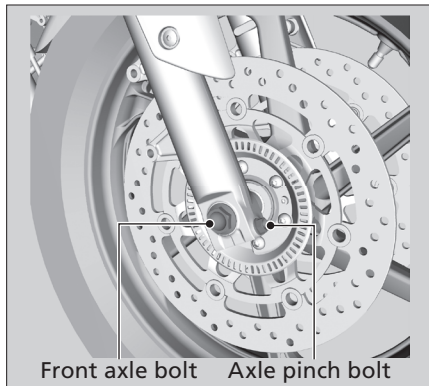

8. Loosen the left axle pinch bolt.
9. On the left side, withdraw the front axle shaft, and remove the side collars and wheel.

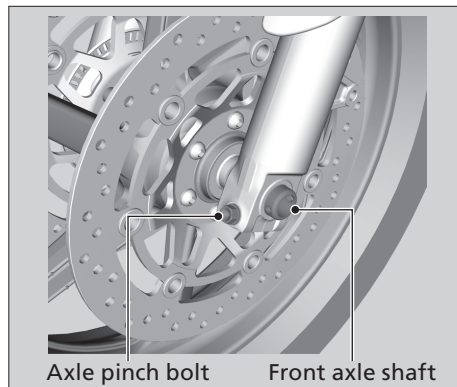

Troubleshooting

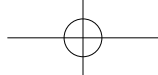

Tyre Puncture ► Removing Wheels

Installation

1. Attach the side collars to the wheel.
2. On the left side, place the wheel between the fork legs and insert the lightly greased front axle shaft to the end, through the left fork leg and wheel hub.
3. Align the index line of the front axle shaft with the surface of the fork leg.

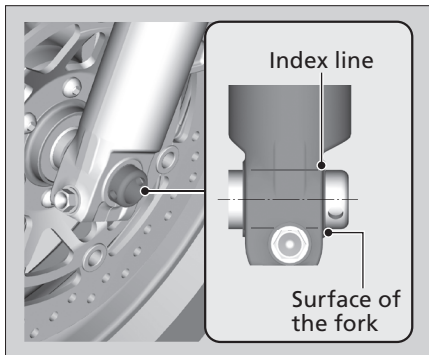

4. Tighten the left axle pinch bolt to hold the axle.

5. Tighten the axle bolt.

Torque: 59 N·m (6.0 kgf·m, 44 lbf·ft).

6. Loosen the left axle pinch bolt.

7. Tighten the right axle pinch bolt.

Torque: 22 N·m (2.2 kgf·m, 16 lbf·ft).

8. Install the right brake caliper and tighten the mounting bolts.

Torque: 31 N·m (3.2 kgf·m, 23 lbf·ft).

Troubleshooting

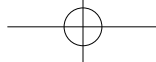

Tyre Puncture ► Removing Wheels

9. Install the left brake caliper and tighten the mounting bolts.

Torque: 31 N·m (3.2 kgf·m, 23 lbf·ft).

- Take care to prevent the brake caliper from scratching the wheel during installation.
- Use new mounting bolts when installing the brake caliper.

NOTICE

When installing the brake calipers into position on the fork legs, carefully fit the brake disc between the pads to avoid scratching them.

10. Lower the front wheel on the ground.
11. Apply the brake lever and brake pedal several times. Then, pump the fork several times.
12. Retighten the left axle pinch bolt.

Torque: 22 N·m (2.2 kgf·m, 16 lbf·ft).

13. Raise the front wheel off the ground again, and check that the wheel rotates freely after you release the brake.
14. Remove the protective tape or cloth.

If a torque wrench was not used for installation, see your dealer as soon as possible to verify proper assembly. Improper assembly may lead to loss of braking capacity.



Tyre Puncture ► Removing Wheels

Rear Wheel

Removal

1. Support your motorcycle securely and raise the rear wheel off the ground using a maintenance stand or a hoist.
2. Loosen the muffler band bolts.
3. Remove the muffler stay bolt, nut and washer.

Troubleshooting

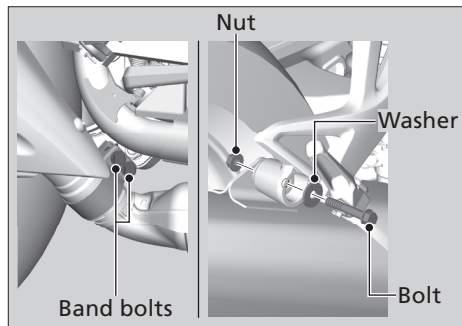

4. Move the muffler outward.
5. Remove the rear wheel nuts, and remove the rear wheel.

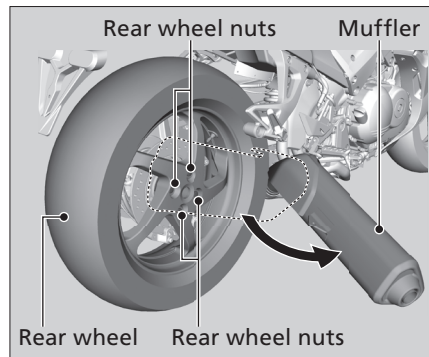

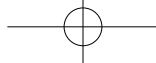

Tyre Puncture ► Removing Wheels

Installation

1. To install the rear wheel, reverse the removal procedure.
2. Tighten the rear wheel nuts equally.

Torque: 108 N·m (11.0 kgf·m, 80 lbf·ft).

3. Tighten the muffler band bolts.

Torque: 21 N·m (2.1 kgf·m, 15 lbf·ft).

4. Check that the wheel rotates freely.

If a torque wrench was not used for installation, see your dealer as soon as possible to verify proper assembly. Improper assembly may lead to loss of braking capacity.

Troubleshooting

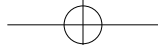

Electrical Trouble

Battery Goes Dead

Charge the battery using a motorcycle battery charger.

Remove the battery from the motorcycle while charging.

Do not use an automobile-type battery charger, as these can overheat a motorcycle battery and cause permanent damage.

If the battery does not recover after recharging, contact your dealer.

NOTICE

Jump starting using an automobile battery is not recommended, as this can damage your motorcycle's electrical system.

Burned-out Light Bulb

Follow the procedure below to replace a burned-out light bulb.

Turn the ignition switch to the OFF or LOCK position.

Allow the bulb to cool before replacing it.

Do not use bulbs other than those specified.

Check the replacement bulb for correct operation before riding.

For the light bulb wattage, see "Specifications". ➤P.113

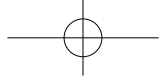

Headlight Bulb

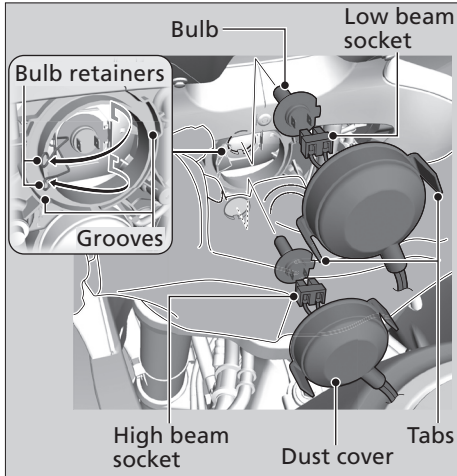

Electrical Trouble ► Burned-out Light Bulb

The high and low beam headlight bulbs replacement can be done in the same way.

1. Remove the dust cover.
2. Pull the socket off the bulb without turning it.
3. Unhook the bulb retainers and pull out the bulb without turning it.
4. Install a new bulb and parts in the reverse order of removal.
 - Make sure the dust cover tabs and headlight housing grooves are aligned.
 - Be careful not to confuse the high beam and low beam headlight sockets.

Do not touch the glass surface with your fingers. If you touch the bulb with your bare hands, clean it with a cloth moistened with alcohol.

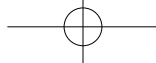

Electrical Trouble ► Burned-out Light Bulb

Position Light

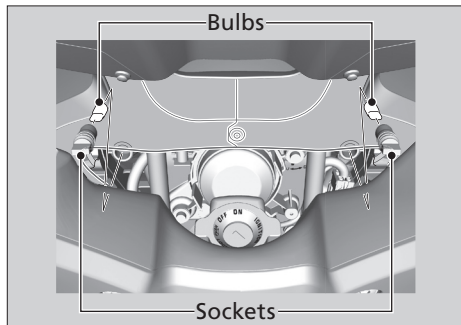

Troubleshooting

1. Pull the socket and remove it.
2. Pull out the bulb without turning.
3. Install a new bulb and parts in the reverse order of removal.

Brake/Tail light

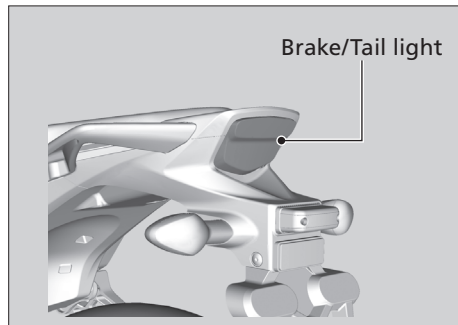

The brake and tail light uses several LEDs. If there is a LED which is not turned on, see your dealer for this service.



Electrical Trouble ► Burned-out Light Bulb

Front/Rear Turn Signal Bulb

1. Remove the screw.
2. Remove the turn signal lens and lens packing.
3. Slightly press the bulb and turn it counterclockwise.

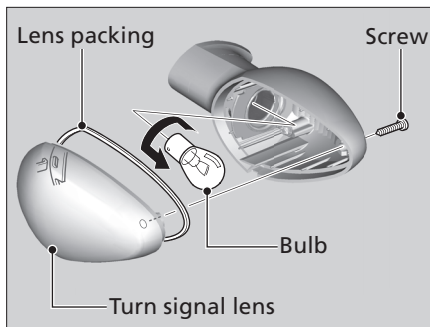

4. Install a new bulb and parts in the reverse order of removal.
► Use only the amber bulb.

License Plate Light

1. Remove the screws.
2. Remove the license light cover and license light cover packing.
3. Pull out the bulb without turning.

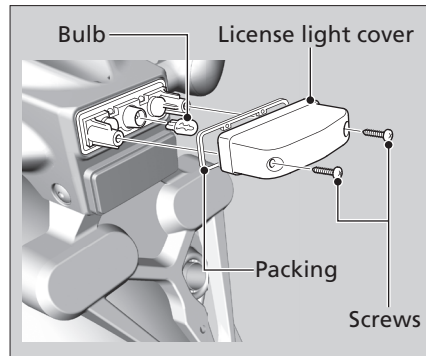

4. Install a new bulb and parts in the reverse order of removal.

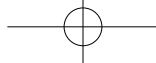

Electrical Trouble ► Blown Fuse

Blown Fuse

Before handling fuses, see “Inspecting and Replacing Fuses”. ►P.46

! Fuse Box Fuses

Troubleshooting

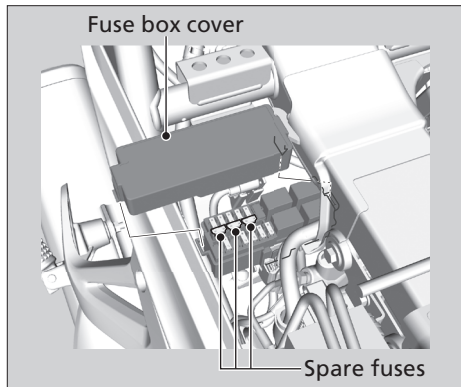

1. Remove the seat. ►P.54
2. Remove the fuse box cover.
3. Pull the fuses out with the fuse puller in the tool kit and check for a blown fuse. Always replace a blown fuse with a spare of the same rating.
4. Reinstall the fuse box cover.
5. Reinstall the seat.



Electrical Trouble ► Blown Fuse

■ Main Fuse & FI Fuse

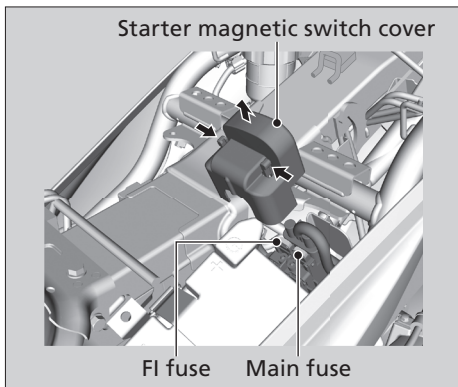

1. Remove the seat. ►P.54
2. Remove the starter magnetic switch cover.
3. Disconnect the wire connector of the starter magnetic switch.

4. Pull the main fuse and FI fuse out with the fuse puller in the tool kit and check for a blown fuse. Always replace a blown fuse with a spare of the same rating.
 - Spare fuses are provided in the fuse box.
5. Reinstall parts in the reverse order of removal.

NOTICE

If a fuse fails repeatedly, you likely have an electrical problem. Have your motorcycle inspected by your dealer.

Troubleshooting

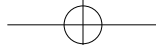

Information

Keys P.99

**Instruments, Controls, &
Other Features** P.100

Fuels Containing Alcohol P.103

Catalytic Converter P.104

Caring for Your Motorcycle P.105

Storing Your Motorcycle P.107

Transporting Your Motorcycle P.108

You & the Environment P.109

Serial Numbers P.110

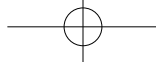

Keys

Keys

Ignition key

The ignition key contains a special coded chip that is recognized by the immobilizer system (HISS) in order to start the engine. Handle the key carefully to prevent damaging the HISS components.

- Do not bend keys or subject them to undue stress.
- Avoid prolonged exposure to sunlight or high temperatures.
- Do not grind, drill or in any way alter their shape.
- Do not expose to strong magnetic objects.

If you lose all keys and the key number plate, the PGM-FI unit/ignition control module must be replaced by your dealer. To avoid this, keep a duplicate key.

If you lose a key, make another duplicate key immediately.

To make a duplicate key and register it with your HISS system, take the spare key, the key number plate, and the motorcycle to your dealer.

A metal key holder may cause damage to the area surrounding the ignition switch.



Instruments, Controls, & Other Features

Instruments, Controls, & Other Features

Ignition Switch

The headlight is always ON when the ignition switch is ON. Leaving the ignition switch ON with the engine stopped will drain the battery.

Do not turn the key while riding.

Engine Stop Switch

Do not use the engine stop switch except in an emergency. Doing so when riding will cause the engine to suddenly turn off, making riding unsafe.

If you stop the engine using the engine stop switch, turn the ignition switch OFF. Failing to do so will drain the battery.

Odometer

The display locks at 999,999 when the read-out exceeds 999,999.

Tripmeter

The tripmeter A returns to 0.0 when the read-out exceeds 999.9.

The tripmeter B returns to 0.0 when the read-out exceeds 9,999.9.

HISS

The Honda Ignition Security System (HISS) immobilizes the engine's ignition system if an improperly-coded key is used to try and start the engine. When the ignition switch is turned OFF, the HISS immobilizer system is always alert, even if the HISS indicator is not flashing. If the ignition switch is turned ON with the engine stop switch in the RUN position, the HISS indicator turns ON and goes off after a few seconds to indicate it is OK to start the engine.

➤ **HISS Indicator Does Not Turn OFF P.80**

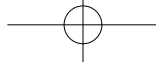

Instruments, Controls, & Other Features

The HISS indicator starts flashing every 2 seconds for 24 hours after the ignition switch is turned OFF. To prevent or to restore the HISS indicator flashing:

1. With the ignition switch ON, press and hold the **A** button (➡P.20) for 2 seconds or more when the display function mode is odometer.
 - ▶ The HISS indicator flashes once.
2. Turn the ignition switch OFF.

EC Directive

This immobilizer system complies with R & TTE (Radio and Telecommunications Terminal Equipment and the mutual recognition of their conformity) Directive.



The declaration of conformity to R & TTE Directive is provided to the owner at the time of purchase. The declaration of conformity should be kept at a safe place. When the declaration of conformity is lost or is not provided, contact your dealer.

South Africa only



Information

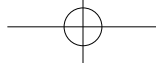

Instruments, Controls, & Other Features

Document Bag

The owner's manual, registration, and insurance information can be stored in the plastic document bag located under the seat.

Ignition Cut-off System

A banking (lean angle) sensor automatically stops the engine and fuel pump if the motorcycle falls over. To reset the sensor, you must turn the ignition switch to OFF and back to the ON position before the engine can be restarted.

Information

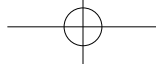

Fuels Containing Alcohol

Fuels Containing Alcohol

Some conventional fuels blended with alcohol are available in some locales to help reduce emissions to meet clean air standards. If you plan to use blended fuel, check that it is unleaded and meets the minimum octane rating requirement.

The following fuel blends can be used in your motorcycle:

- Ethanol (ethyl alcohol) 10 % by volume (max).
- Petrol containing ethanol may be marketed under the name Gasohol.
- Methanol (methyl alcohol) 5 % by volume (max) that contain cosolvents and corrosion inhibitors to protect the fuel system. Never use a blend containing more than 5 %.

The use of petrol containing more than 10 % ethanol (or more than 5 % methanol) may:

- Damage the painting of the fuel tank.
- Damage the rubber tubes of the fuel line.
- Cause corrosion of the fuel tank.
- Cause poor drivability.

NOTICE

Use of blended fuels containing higher than approved percentages can damage metal, rubber, plastic parts of your fuel system.

If you notice any undesirable operating symptoms or performance problems, try a different brand of petrol.

Information



Catalytic Converter

Catalytic Converter

This motorcycle is equipped with a three-way catalytic converter. The catalytic converter contains precious metals that serve as catalysts in high temperature chemical reactions that convert hydrocarbons (HC), carbon monoxide (CO), and oxides of nitrogen (NOx) in the exhaust gasses into safe compounds.

A defective catalytic converter contributes to air pollution and can impair your engine's performance. A replacement unit must be an original Honda part or equivalent.

Information

Follow these guidelines to protect your motorcycle's catalytic converter.

- Always use unleaded petrol. Leaded petrol will damage the catalytic converter.
- Keep the engine in good running condition.
- Have your motorcycle serviced if your engine is misfiring, backfiring, stalling, or otherwise not running properly, stop riding and turn off the engine.

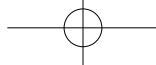

Caring for Your Motorcycle

Caring for Your Motorcycle

Frequent cleaning and polishing is important to ensure the life of your Honda. A clean motorcycle makes it easier to spot potential problems.

In particular, seawater and salts used to prevent ice on roads promote the formation of corrosion. Always wash your motorcycle thoroughly after riding on coastal or treated roads.

Washing

Allow the engine, muffler, brakes, and other high-temperature parts to cool before washing.

1. Rinse your motorcycle thoroughly using a garden hose to remove loose dirt.
2. If necessary, use a sponge or a soft towel with mild cleaner to remove road grime.
 - ▶ Clean the windscreen, headlight lens, panels, and other plastic components with extra care to avoid scratching them.

Avoid directing water into the air cleaner, muffler, and electrical parts.

3. Thoroughly rinse your motorcycle with plenty of clean water.
4. After the motorcycle dries, lubricate any moving parts.
 - ▶ Make sure that no lubricant spills onto the brakes or tyres. Brake discs or pads contaminated with oil will suffer greatly reduced braking effectiveness and can lead to a crash.
5. Lubricate the drive chain immediately after washing and drying the motorcycle.
6. Apply a coat of wax to prevent corrosion.
 - ▶ Avoid products that contain harsh detergents or chemical solvents. These can damage the metal, paint, and plastic on your motorcycle.
Keep the wax clear of the tyres and brakes.
 - ▶ If your motorcycle has any matte painted parts, do not apply a coat of wax to the matte painted surface.

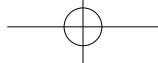

Caring for Your Motorcycle

Washing Precautions

Follow these guidelines when washing:

- Do not use high-pressure washers:
 - ▶ High-pressure water cleaners can damage moving parts and electrical parts, rendering them inoperable.
- Do not direct water at the muffler:
 - ▶ Water in the muffler can prevent starting and causes rust in the muffler.
- Dry the brakes:
 - ▶ Water adversely affects braking effectiveness. After washing, apply the brakes intermittently at low speed to help dry them.
- Do not direct water under the seat:
 - ▶ Water in the underseat compartment can damage your documents and other belongings.

- Do not direct water at the air cleaner:
 - ▶ Water in the air cleaner can prevent the engine from starting.
- Do not direct water near the headlight:
 - ▶ Any condensation inside the headlight should dissipate after a few minutes of running the engine.

Aluminium Components

Aluminium will corrode from contact with dirt, mud, or road salt. Clean aluminium parts regularly and follow these guidelines to avoid scratches:

- Do not use stiff brushes, steel wool, or cleaners containing abrasives.
- Avoid riding over or scraping against curbs.

Panels and Windscreen

Follow these guidelines to prevent scratches and blemishes:

- Wash gently using a soft sponge and plenty of water.

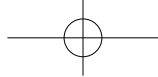

Storing Your Motorcycle

- To remove stubborn stains, use diluted detergent and rinse thoroughly with plenty of water.
- Avoid getting petrol, brake fluid, or detergents on the instruments, windscreen, panels, or headlight.

Exhaust Pipe and Muffler

The exhaust is made of stainless steel, which can become tarnished with burn marks if splattered with oil or other substances when hot. To remove burn marks, use a mild abrasive compound. To remove dirt and mud, use a kitchen cleaning solution for stainless steel and wash with a soft sponge. Rinse with plenty of water to remove all residue.

NOTICE

Even though the exhaust is made of stainless steel, it can become stained. Remove all marks and blemishes as soon as they are noticed.

Storing Your Motorcycle

If you store your motorcycle outdoors, you should consider using a full-body motorcycle cover.

If you won't be riding for an extended period, follow these guidelines:

- Wash your motorcycle and wax all painted surfaces (except matte painted surfaces). Coat chrome pieces with rust-inhibiting oil.
- Lubricate the drive chain. ➤P.49
- Place your motorcycle on a maintenance stand and position a block so that both tyres are off the ground.
- After rain, remove the body cover and allow the motorcycle to dry.
- Remove the battery (➤P.60) to prevent discharge. Charge the battery in a shaded, well-ventilated area.
 - ▶ If you leave the battery in place, disconnect the negative ⊖ terminal to prevent discharge.

continued 107

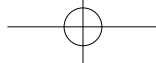

Transporting Your Motorcycle

After removing your motorcycle from storage, inspect all maintenance items required by the Maintenance Schedule.

Information

Transporting Your Motorcycle

If your motorcycle needs to be transported, it should be carried on a motorcycle trailer or a flatbed truck or trailer that has a loading ramp or lifting platform, and motorcycle tie-down straps. Never try to tow your motorcycle with a wheel or wheels on the ground.

NOTICE

Towing your motorcycle can cause serious damage to the transmission.



You & the Environment

You & the Environment

Owning and riding a motorcycle can be enjoyable, but you must do your part to protect the environment.

Choose Sensible Cleaners

Use a biodegradable detergent when you wash your motorcycle. Avoid aerosol spray cleaners that contain chlorofluorocarbons (CFCs) which damage the atmosphere's protective ozone layer.

Recycle Wastes

Put oil and other toxic wastes in approved containers and take them to a recycling centre. Call your local or state office of public works or environmental services to find a recycling centre in your area, and to get instructions on how to dispose of non-recyclable wastes. Do not place used engine oil in the trash, or pour

it down a drain or on the ground. Used oil, petrol, coolant, and cleaning solvents contain poisons that can hurt refuse workers and contaminate drinking water, lakes, rivers, and oceans.



Serial Numbers

Serial Numbers

The frame and engine serial numbers uniquely identify your motorcycle and are required in order to register your motorcycle. They may also be required when ordering replacement parts.

The frame number is stamped on the right side of the steering head.

The engine number is stamped on top of the crankcase.

You should record these numbers and keep them in a safe place.

Information

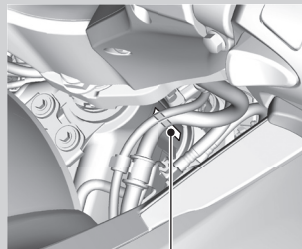

Frame number

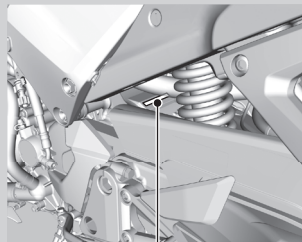

Engine number

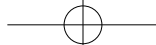

Specifications

■ Main Components

Type	RC60
Overall length	2,130 mm (83.9 in)
Overall width	800 mm (31.5 in)
Overall height	1,240 mm (48.8 in)
Wheelbase	1,465 mm (57.7 in)
Minimum ground clearance	140 mm (5.5 in)
Caster angle	25° 45'
Trail	96 mm (3.8 in)
Curb weight	238 kg (525 lb)
Maximum weight capacity ¹	195 kg (430 lb)
Maximum luggage weight ²	33 kg (73 lb)
Passenger capacity	Rider and 1 passenger
Minimum turning radius	2.80 m (9.19 ft)

*1 Including rider, passenger, all luggage, and accessories

*2 Includes the weight of the luggage and added accessories.

Displacement	782 cm ³ (47.70 cu-in)
Bore x stroke	72 x 48 mm (2.83 x 1.89 in)
Compression ratio	11.6 : 1
Fuel	Unleaded petrol Recommended: 91 RON or higher
Tank capacity	21 litres (5.55 US gal, 4.62 Imp gal)
Battery	12V-10Ah (10 HR) or 12V-11Ah (10 HR) / 11.6Ah (20 HR)
Gear ratios	1st 2.846
	2nd 2.062
	3rd 1.578
	4th 1.291
	5th 1.111
	6th 0.965
Reduction ratios (primary / final)	1.939 / 2.687

Specifications



Specifications

■ Service Data

Tyre size	Front	120/70R17M/C 58V
	Rear	180/55R17M/C 73V
Tyre type	Radial, tubeless	
Recommended Tyres	Front	PIRELLI SCORPION TRAIL
	Rear	PIRELLI SCORPION TRAIL
Tyre air pressure	Front	225 kPa (2.25 kgf/cm ² , 33 psi)
	Rear	250 kPa (2.50 kgf/cm ² , 36 psi)
Minimum tread depth	Front	1.5 mm (0.06 in)
	Rear	2.0 mm (0.08 in)
Spark plugs	(standard)	IMR9D-9H (NGK) or VNH27ZB (DENSO)
Spark plug gap	(non-adjustable)	0.80 to 0.90 mm (0.031 to 0.035 in)
Idle speed	1,200 ± 100 rpm	
Recommended engine oil	Honda 4-stroke motorcycle oil API Service Classification SG or higher, excluding oils marked as "Energy Conserving," SAE 10W-30, JASO T 903 standard MA	

Engine oil capacity	After draining	2.9 litres (3.1 US qt, 2.6 Imp qt)
	After draining & engine oil filter change	3.1 litres (3.3 US qt, 2.7 Imp qt)
	After disassembly	3.8 litres (4.0 US qt, 3.3 Imp qt)
Recommended brake (clutch) fluid	Honda DOT 4 Brake Fluid	
Cooling system capacity	2.92 litres (3.09 US qt, 2.57 Imp qt)	
Recommended coolant	Pro Honda HP Coolant	



Specifications

Recommended drive chain lubricant	Drive chain lubricant designed specifically for O-ring chains	
Drive chain slack	30 to 40 mm (1.2 to 1.6 in)	
Standard drive chain	DID 50VA8 or RK 50HFOZ5	
	No. of links	110
Standard sprocket sizes	Engine sprocket	16T
	Rear wheel sprocket	43T

■ Bulbs

Headlight	12V-55W x 2
Brakelight	LED
Tail light	LED
Front turn signal lights	12V-21W x 2
Rear turn signal lights	12V-21W x 2
Position light	12V-5W x 2
License plate light	12V-5W

■ Fuses

Main fuse	30A
Other fuses	30A, 20A, 10A

■ Torque Specifications

Engine oil drain bolt	30 N·m (3.1 kgf·m, 22 lbf·ft)
Oil filter	26 N·m (2.7 kgf·m, 19 lbf·ft)
Bearing holder pinch bolt	74 N·m (7.5 kgf·m, 55 lbf·ft)
Front wheel axle bolt	59 N·m (6.0 kgf·m, 44 lbf·ft)
Front wheel brake caliper mounting bolts	31 N·m (3.2 kgf·m, 23 lbf·ft)
Front wheel axle pinch bolts	22 N·m (2.2 kgf·m, 16 lbf·ft)
Rear wheel nuts	108 N·m (11.0 kgf·m, 80 lbf·ft)
Muffler band bolts	21 N·m (2.1 kgf·m, 15 lbf·ft)

Specifications

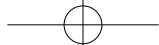

Index ▶ A to D

A

ABS Indicator.....	30
Accessories.....	16

B

Battery.....	45, 60
Brakelight Switch.....	78

Brakes

Fluid.....	48, 67
Pad Wear.....	68
Lever Adjustment.....	75

Braking.....	12
--------------	----

Bulb

Brake/Tail Light.....	94
Front/Rear Turn Signal.....	95
Headlight.....	93
License Plate Light.....	95
Position Light.....	94

C

Caring for Your Motorcycle.....	105
---------------------------------	-----

Clip A.....	55
-------------	----

Clip B.....	55
-------------	----

Clip C.....	56
-------------	----

Clutch

Fluid.....	48, 69
------------	--------

Lever Adjustment.....	75
-----------------------	----

Colour Label.....	44
-------------------	----

Combined ABS.....	13
-------------------	----

Compartment

Owner's Manual.....	37, 102
---------------------	---------

Tool Kit.....	37, 53
---------------	--------

Coolant.....	49, 65
--------------	--------

Coolant Temperature Gauge.....	22
--------------------------------	----

D

Digital Clock Adjustment.....	29
-------------------------------	----

Drive Chain.....	71
------------------	----



E	
Electrical Trouble	92
Engine	
Number	110
Oil	47, 61
Oil Filter	63
Overheats	81
Starting	34
Stop Switch	32, 34, 100
Stopping	100
Environment	109
F	
Flooded Engine	34
Frame Number	110
Front Brake Lever Adjustment	75
Fuel	
Gauge	21
Recommended	36
Remaining	21
Tank Capacity	36
Fuels Containing Alcohol	103
Fuses	46, 96

G	
Gasohol	103
H	
Hazard Switch	32
Headlight Aim	77
Headlight Dimmer Switch	32
Helmet Holder	37
High Beam Indicator	31
High Coolant Temperature	
Indicator	22, 81
HISS Indicator	30, 80
Horn Button	32

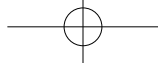

Index ► I to P

I

Idle speed	78
Ignition Cut-off System	
Banking Sensor	102
Side Stand	70
Ignition Key	99
Ignition Switch	33, 34
Image Labels	6
Indicators	30
Instruments	20

L

Labels	6
Left Rear Cowl	59
Load Limits	17
Loading Guidelines	17
Low Oil Pressure Indicator	22, 82

M

Maintenance	
Fundamentals	43
Importance	39
Safety	39

Schedule	40
Maximum Weight Limit	17
Modifications	16

N

Neutral Indicator	31
-------------------------	----

O

Odometer	23, 100
Oil	
Engine	47, 61
Overheating	81

P

Parking	14
Parts Location	18
Passing light control switch	32
Petrol	36, 103
PGM-FI (Programmed Fuel Injection)	
malfunction indicator lamp (MIL) ...	30, 82
Protective Apparel	11

**R****Recommended**

Coolant.....	49
Fuel.....	36
Oil.....	47

Refuelling.....	36
------------------------	-----------

Removal

Clip A.....	55
Clip B.....	55
Clip C.....	56
Left Rear Cowl.....	59
Right Front Side Cowl.....	57
Seat.....	54

Repair Kit.....	85
------------------------	-----------

Riding Precautions.....	12
--------------------------------	-----------

Right Front Side Cowl.....	57
-----------------------------------	-----------

S

Safety Precautions.....	11
--------------------------------	-----------

Seat.....	54
------------------	-----------

Serial Numbers.....	110
----------------------------	------------

Shifting Gears.....	35
----------------------------	-----------

Side Stand.....	70
------------------------	-----------

Side Stand Ignition Cut-off System.....	70
--	-----------

Specifications.....	111
----------------------------	------------

Speedometer.....	21
-------------------------	-----------

Start Button.....	32, 34
--------------------------	---------------

Starting the Engine.....	34
---------------------------------	-----------

Steering Lock.....	33
---------------------------	-----------

Stopping Engine.....	100
-----------------------------	------------

Storage

Equipment.....	37
----------------	----

Owner's Manual.....	37, 102
---------------------	---------

Storing Your Motorcycle.....	107
-------------------------------------	------------

Switches.....	32
----------------------	-----------

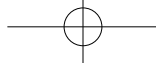

Index ► T to W

T

Tachometer	21
Throttle.....	74
Tool Kit	53
Transporting Your Motorcycle.....	108
Tripmeter	23
Troubleshooting	79
Turn signal indicators	31

Tyres

Air Pressure	50
Puncture	85
Replacing	50, 85

W

Warning Indicators ON.....	31, 81, 82
Washing Your Motorcycle.....	105
Weight Limit.....	17
Wheels	
Front removal.....	86
Rear removal	90

Index